

# MEF

## Implementation Agreement

### MEF 22.1

#### Mobile Backhaul Phase 2

**January 2012**

## Disclaimer

The information in this publication is freely available for reproduction and use by any recipient and is believed to be accurate as of its publication date. Such information is subject to change without notice and the Metro Ethernet Forum (MEF) is not responsible for any errors. The MEF does not assume responsibility to update or correct any information in this publication. No representation or warranty, expressed or implied, is made by the MEF concerning the completeness, accuracy, or applicability of any information contained herein and no liability of any kind shall be assumed by the MEF as a result of reliance upon such information.

The information contained herein is intended to be used without modification by the recipient or user of this document. The MEF is not responsible or liable for any modifications to this document made by any other party.

The receipt or any use of this document or its contents does not in any way create, by implication or otherwise:

any express or implied license or right to or under any patent, copyright, trademark or trade secret rights held or claimed by any MEF member company which are or may be associated with the ideas, techniques, concepts or expressions contained herein; nor

any warranty or representation that any MEF member companies will announce any product(s) and/or service(s) related thereto, or if such announcements are made, that such announced product(s) and/or service(s) embody any or all of the ideas, technologies, or concepts contained herein; nor

any form of relationship between any MEF member companies and the recipient or user of this document.

Implementation or use of specific Metro Ethernet standards or recommendations and MEF specifications will be voluntary, and no company shall be obliged to implement them by virtue of participation in the Metro Ethernet Forum. The MEF is a non-profit international organization accelerating industry cooperation on Metro Ethernet technology. The MEF does not, expressly or otherwise, endorse or promote any specific products or services.

© The Metro Ethernet Forum 2012. All Rights Reserved.

## Table of Contents

<b>1.</b>	<b>Abstract.....</b>	<b>1</b>
<b>2.</b>	<b>Terminology.....</b>	<b>2</b>
<b>3.</b>	<b>Introduction .....</b>	<b>5</b>
<b>4.</b>	<b>Mobile Network Topologies .....</b>	<b>6</b>
<b>5.</b>	<b>Scope .....</b>	<b>10</b>
5.1	In Scope .....	10
5.2	Out of Scope .....	10
<b>6.</b>	<b>Compliance Levels .....</b>	<b>10</b>
<b>7.</b>	<b>Mobile Backhaul Service Model .....</b>	<b>11</b>
7.1	Service Model Use Cases.....	12
7.1.1	Use Case 1: RAN CE with TDM Demarcation.....	12
7.1.1.1	<i>Specific Requirements related to Use Case 1:</i> .....	13
7.1.2	Use Case 2: RAN CE with Ethernet (MEF UNI) Demarcation .....	13
7.1.3	Common Requirements related to Use Cases 1 and 2.....	14
7.2	Applying MEF Service Definitions to Mobile Backhaul .....	15
7.2.1	Ethernet Private Line Service.....	16
7.2.2	Ethernet Virtual Private Line Service .....	17
7.2.3	Ethernet Private LAN Service.....	18
7.2.4	Ethernet Virtual Private LAN Service .....	19
7.2.5	Ethernet Private Tree Service.....	20
7.2.6	Ethernet Virtual Private Tree Service.....	21
<b>8.</b>	<b>Management Model for Mobile Backhaul Service.....</b>	<b>22</b>
8.1	Ethernet OAM .....	22
8.2	Service OAM.....	23
<b>9.</b>	<b>Resiliency related Performance Attributes for EVC .....</b>	<b>24</b>
9.1	Short Term Disruptions .....	25
9.2	Diversity.....	26
9.2.1	ETH-layer Diversity .....	27
9.2.2	Availability for Diverse Group.....	28
<b>10.</b>	<b>UNI Requirements .....</b>	<b>29</b>
10.1	UNI Type .....	29
10.2	GIWF's UNI Requirements .....	30
10.3	UNI Resiliency .....	31
10.4	UNI PHY for Synchronization Service.....	31
10.4.1	UNI PHY with Synchronous mode.....	32
10.4.2	ESMC Protocol (L2CP) on UNI PHY .....	33
10.4.3	QL process support on UNI PHY in Synchronous mode.....	34
10.5	UNI Service Attributes .....	35
10.5.1	VLAN based MEF 6.1 Services.....	36

10.5.2	Port based MEF 6.1 Services .....	37
<b>11.</b>	<b>EVC Requirements .....</b>	<b>39</b>
11.1	Maximum Number of UNIs.....	39
11.2	EVC MTU .....	40
11.3	Set of ordered UNI pairs.....	40
11.4	EVC Performance.....	40
11.4.1	Performance for Synchronization Traffic Class.....	41
11.4.2	Performance with MEN Resiliency.....	42
11.4.3	Performance with RAN Resiliency .....	42
11.5	Class of Service for Mobile Backhaul .....	44
11.5.1	CoS Names.....	45
11.5.2	CoS Performance Objectives (CPO).....	48
11.6	EVC per UNI and per EVC Service Attributes .....	50
11.6.1	VLAN based MEF 6.1 Services.....	51
11.6.2	Port based MEF 6.1 Services .....	53
<b>12.</b>	<b>Synchronization .....</b>	<b>55</b>
12.1	Performance of synchronization architecture .....	57
12.2	Packet Based Methods .....	58
12.2.1	Network (UNI-N) Interface Limits for Packet based Methods .....	59
12.2.2	Network (UNI-N) Interface Limits for Packet based Methods – Special Case.....	59
12.2.3	CES timing requirements .....	59
12.2.3.1	<i>Network (TDM Interface) Interface Limits at Output of GIWF .....</i>	<i>60</i>
12.2.3.2	<i>Network (TDM Interface) Interface Limits at Input of GIWF .....</i>	<i>60</i>
12.3	Synchronous Ethernet Methods .....	60
12.3.1	Network (UNI-N) Interface Limits for Synchronous Ethernet Methods .....	61
12.3.2	Network (UNI-N) Interface Limits - Special Cases.....	61
<b>13.</b>	<b>References.....</b>	<b>63</b>
<b>Appendix A.</b>	<b>Generic Inter-working Function (Informative).....</b>	<b>67</b>
<b>Appendix B.</b>	<b>Mobile Backhaul User Traffic Classes (Informative).....</b>	<b>68</b>
<b>Appendix C.</b>	<b>Mobile Backhaul Services (Informative).....</b>	<b>71</b>
C.1	Use Case 1: EVP Line per RAN BS.....	71
C.2	Use Case 2: EVP Tree per group of RAN BSs.....	73
C.3	Use Case 3: EVP LAN per group of RAN BSs.....	75
C.4	Use Case 4: EVP Tree per Service .....	76
C.5	Use Case 5: Different EVC for different mobile interfaces.....	78
C.6	Configuration alternatives for Management plane .....	80

**List of Figures**

Figure 1 - Example of topology when centralized radio control functions .....	7
Figure 2 - Example of topology for LTE with decentralized radio control functions .....	8
Figure 3: Example of topology for WIMAX with decentralized radio control functions .....	9
Figure 4 : Single Domain Mobile Backhaul Reference Model .....	11
Figure 5: Use Case 1a – Low Priority traffic using CES across MEN .....	12
Figure 6: Use Case 1b – All traffic with CES across MEN .....	13
Figure 7: Use Case 2a – Low priority traffic with MEF 6.1 Service across MEN .....	13
Figure 8: Use Case 2b – All traffic with MEF 6.1 Service across MEN.....	14
Figure 9: MEF 6.1 Service for connectivity between any RAN CEs .....	14
Figure 10: Ethernet Private Line (EPL) Service .....	17
Figure 11: Ethernet Virtual Private Line (EVPL) Service .....	18
Figure 12: Ethernet Private LAN (EP-LAN) Service.....	19
Figure 13: Ethernet Virtual Private LAN (EVP-LAN) Service.....	20
Figure 14: Ethernet Private Tree (EP-Tree) Service.....	21
Figure 15: Ethernet Virtual Private Tree (EVP-Tree) Service .....	22
Figure 16: FM and PM Reference Model for Use Case 2.....	23
Figure 17: Association of EVC to two SP ECs for improved resiliency .....	25
Figure 18: RAN based Resiliency using diverse EVCs and optionally diverse UNIs.....	43
Figure 19: Partial diversity with common UNI at RAN BS site .....	44
Figure 20: Synchronization Distribution Models from PRC source to RAN BS UNI.....	57
Figure 21: Use cases for packet method to distribute reference timing .....	58
Figure 22: Example of Synchronization Service using Synchronous Ethernet .....	61
Figure 24: EVP Line per RAN BS – Use Case 1.....	72
Figure 25: EVP-Tree per group of RAN BSs – Use Case 2.....	74
Figure 26: EVP-LAN per group of RAN BSs – Use Case 3.....	76
Figure 27: CE-VLAN ID per service – Use Case 4 .....	77
Figure 28: EVP-LAN for X2 and EVP-Line for S1 – Use Case 5 .....	79
Figure 29: Ethernet Service for Management plane .....	81
Figure 30: Multiple CoS IDs on the EVC reserved for Management traffic .....	82

**List of Tables**

Table 1: Terminology .....	5
Table 2: UNI Physical layer attribute – Mode .....	32
Table 3: ESMC Protocol.....	33
Table 4: QL process support in Synchronous operation mode .....	34
Table 5: Per UNI Service Attributes for VLAN based MEF 6.1 [3] Services .....	37
Table 6: Per UNI Service Attributes for Port based MEF 6.1 [3] Services .....	39
Table 7: Examples of MBH Traffic Classes mapping to CoS Names in MEN .....	45
Table 8: One way CPOs across PT for Point-to-Point Mobile Backhaul service .....	50
Table 9: EVC per UNI Service Attributes for VLAN based MEF 6.1 [3] Services .....	51
Table 10: Per EVC Service Attributes for VLAN based MEF 6.1 [3] Services .....	52
Table 11 EVC per UNI Service Attributes for Port based MEF 6.1 [3] Services.....	53
Table 12 Per EVC Service Attributes for Port based MEF 6.1 [3] Services .....	54
Table 13: Mobile Technology Synchronization Requirements .....	56
Table 15: WiMAX User Service Classes (IEEE 802.16 [27]) .....	68
Table 16: Standardized QCI Characteristics for LTE Service Classes 3GPP TS 23.203 [61] .....	69
Table 17: EVP Line per RAN BS – Use Case 1 .....	72
Table 18: Example of CE-VLAN ID \ EVC mapping both at RAN BS UNI-N and at RAN NC UNI-N.....	73
Table 19: Example of multiple CoS IDs based on <EVC+PCP> – Use Case 1.....	73
Table 20: EVP Tree per group of RAN BSs – Use Case 2.....	75
Table 21: EVP LAN per group of RAN BSs – Use Case 3.....	76
Table 22: EVP Tree per Service – Use Case 4.....	77
Table 23: Example of CE-VLAN ID\EVC mapping both at RAN BS UNI-N and at RAN NC UNI-N.....	77
Table 24: CoS ID both per <EVC> and per <EVC+PCP> - Use Case 4.....	78
Table 25: EVP Tree per group of RAN BSs – Use Case 5.....	79
Table 26: Example of CE-VLAN ID \ EVC mapping both at RAN BS UNI-N and at RAN NC UNI-N.....	80
Table 27: Ethernet Service configuration for Management plane – An example .....	81
Table 28: Example of Multiple CoS IDs on the EVC reserved to Management .....	82

## **1. Abstract**

This document identifies the requirements for MEF Ethernet Services and MEF External Interfaces (EIs such as UNIs) for use in Mobile Backhaul networks based on MEF specifications. In addition, new interface and service attributes have been specified where needed. The services and requirements in this Implementation Agreement are based on the services defined in MEF 6.1 [3] as well as the attributes in MEF 10.2 [7], in MEF 10.2.1 [8] and this IA. The aim is to be flexible to support a wide range of Ethernet service based mobile network deployments.

## 2. Terminology

Term	Definition	Reference
3GPP	3 <sup>rd</sup> Generation Partnership Project	3GPP TS 21.905 [57]
A	Availability	MEF 10.2 [7] MEF 10.2.1 [8]
ACR	Adaptive Clock Recovery	ITU-T G.8260 [31] RFC 4197 [85]
aGW	Access Gateway in Wimax or LTE networks. Also referred to as Access Service Network (ASN) Gateway in Wimax and S-GW/MME in LTE. In this IA aGW is one of the options for a RAN NC	WMF-T32-001 [86] NGMN Alliance [88]
ASP	Application Service Provider	WMF-T32-001 [86]
ATS	Abstract Test Suite	MEF 9 [6]
BSC	Base Station Controller	3GPP TS 21.905 [57]
BTS	Base Transceiver Station	3GPP TS 21.905 [57]
CBS	Committed Burst Size	MEF 10.2 [7]
CIR	Committed Information Rate	MEF 10.2 [7]
CDMA	Code Division Multiple Access	TIA IS-2000.1 [52]
CE	Customer Edge	MEF 10.2 [7]
CEN	Carrier Ethernet Network (used interchangeably with Metro Ethernet Network, MEN). Also referred to as MEN Operator or MEN Service Provider. The entity providing the backhaul service for a Mobile Operator.	MEF 12.1 [10]
CES	Circuit Emulation Services	MEF 3 [1]
CHLI	Consecutive High Loss Intervals	MEF 10.2.1 [8]
CF	Coupling Flag	MEF 10.2 [7]
CM	Coupling Mode	MEF 10.2 [7]
CoS Frame Set	<b>Class of Service Frame Set:</b> A set of Frames that have a commitment from the Operator or Service Provider subject to a particular set of performance objectives.	MEF 23.1 [18]
CoS ID	<b>Class of Service Identifier.</b> The mechanism and/or values of the parameters in the mechanism to be used to identify the CoS Name that applies to the frame at a given External Interface (EI). See MEF 23.1 for options.	MEF 23.1 [18] MEF 10.2 [7]
CoS Label	<b>Class of Service Label:</b> A CoS Name that is standardized in MEF 23.1. Each CoS Label identifies four Performance Tiers where each Performance Tier contains a set of performance objectives and associated parameters.	MEF 23.1 [18]
CoS Name	<b>Class of Service Name:</b> A designation given to one or more sets of performance objectives and associated parameters by the Service Provider or Operator.	MEF 23.1 [18]
CPO	<b>CoS Performance Objective.</b> An objective for a given performance metric	MEF 23.1 [18]
CSP	Communication Service Provider	WMF-T32-001 [86]



Term	Definition	Reference
Color-aware	A Bandwidth Profile property where a pre-determined level of Bandwidth Profile compliance for each Frame, indicated by the Color Identifier, is taken into account when determining the level of compliance for each Service Frame.	MEF 10.2 [7] MEF 23.1 [18]
Color Id	<b>Color Identifier.</b> The mechanism and/or values of the parameters in the mechanism used to identify the Color that applies to the frame at a given UNI.	MEF 23.1 [18]
DNU	Don not use	ITU-T G.781[39]
DSCP	Differentiated Services Code Point	MEF 10.2 [7] RFC 2474 [82]
EBS	Excess Burst Size	MEF 10.2 [7]
EC	Ethernet Connection	MEF 12.1 [10]
EEC	Ethernet Equipment Clock	ITU-T G.8262 [33]
E-BWP	<b>Egress Bandwidth Profile.</b> A service attribute that specifies the length and arrival time characteristics of egress Service Frames at the egress UNI.	MEF 10.2 [7]
EIR	Excess Information Rate	MEF 10.2 [7]
eNB	Evolved Universal Terrestrial Radio Access Network (E-UTRAN) Node B is the Radio Base Station in LTE. Also referred to as eNodeB or eNB. In this IA an eNodeB is one of the options for a RAN BS	3GPP TS 36.300 [74]
EPL	Ethernet Private Line	MEF 6.1 [3]
EVC	Ethernet Virtual Connection	MEF 10.2 [7]
EVPL	Ethernet Virtual Private Line	MEF 6.1 [3]
EP-LAN	Ethernet Private LAN	MEF 6.1 [3]
EP-Tree	Ethernet Private Tree	MEF 6.1 [3]
ESMC	Ethernet Synchronization Message Channel	ITU-T G.8264 [34]
ESMC Frame	A Frame exchanged between a MEN and the RAN CE when UNI PHY is in synchronous operation mode	ITU-T G.8264 [34]
ESRG	ETH-layer SRG	This IA
EVP-LAN	Ethernet Virtual Private LAN	MEF 6.1 [3]
EVP-Tree	Ethernet Virtual Private Tree	MEF 6.1 [3]
EI	External Interface	MEF 12.1 [10]
FD	Frame Delay	MEF 10.2 [7]
FDR	<b>Frame Delay Range.</b> The difference between the observed percentile of delay at a target percentile and the observed minimum delay for the set of frames in time interval T.	Adapted from MEF 10.2 [7] MEF 23.1[18]
FDV	Frame Delay Variation	MEF 10.2 [7]
FLR	Frame Loss Ratio	MEF 10.2 [7]
FM	Fault Management	MEF 17 [14] MEF 30 [22]
GIWF	Generic Inter-working Function	This IA
GSM	Global System for Mobile communication	GSM 01.04 [51]
HLI	High Loss Interval	MEF 10.2.1 [8]
IA	Implementation Agreement	This IA
IFDV	Inter Frame Delay Variation	MEF 10.2 [7]

Term	Definition	Reference
<b>I-BWP</b>	<b>Ingress Bandwidth Profile.</b> A characterization of ingress Service Frame arrival times and lengths at the ingress UNI and a specification of disposition of each Service Frame based on its level of compliance with the characterization.	MEF 10.2 [7]
<b>IP</b>	Internet Protocol. IPv4 is for version 4 (RFC 791) and IPv6 is for version 6 (RFC 2460)	RFC 791 [77] RFC 2460 [81]
<b>IPSec</b>	Internet Protocol Security	RFC 2401 [80]
<b>L2CP</b>	Layer 2 Control Protocol	MEF 10.2 [7]
<b>LTE</b>	Long Term Evolution	3GPP TS 36.300 [74]
<b>MBSFN</b>	Multimedia Broadcast Multicast Service (MBMS) Single Frequency Network support	3GPP TS 25.346
<b>MEG</b>	Maintenance Entity Group	MEF 17 [14]
<b>MEP</b>	MEG End Point	MEF 17 [14]
<b>MFD</b>	Mean Frame Delay	MEF 10.2 [7]
<b>MME</b>	Mobility Management Entity is an LTE function and located in the Network Controller site. In this IA MME is included when referring to a RAN NC	3GPP TS 36.300 [74]
<b>Mobile Operator</b>	The entity obtaining the Backhaul service from a SP or MEN Operator. Also referred to as Subscriber in this IA	This IA
<b>MTU</b>	Maximum Transmission Unit	MEF 10.2 [7]
<b>NE</b>	A Metro Ethernet Network Element (ME-NE) supporting MEF Services	MEF 4 [2]
<b>N/S</b>	Not specified	This IA
<b>NodeB</b>	WCDMA Radio Base Station. In this IA a NodeB is one of the options for a RAN BS	3GPP TS 21.905 [57]
<b>NSP</b>	Network Service Provider	WMF-T32-001 [86]
<b>NTP</b>	Network Time Protocol	RFC 1305 [78]
<b>OAM</b>	Operations, Administration, and Maintenance	MEF 17 [14]
<b>PCEF</b>	Policy and Charging Enforcement Function	3GPP TS 23.203 [61]
<b>PCP</b>	Priority Code Point	IEEE 802.1Q-2005 [24]
<b>PEC</b>	Packet based Equipment Clocks	ITU-T G.8261 [32]
<b>PDH</b>	Plesiochronous Digital Hierarchy	ITU-T G.705 [50]
<b>PM</b>	Performance Monitoring	MEF 17 [14]
<b>PRC</b>	Primary Reference Clock	ITU-T G.811 [42]
<b>PT</b>	Performance Tier for CoS Performance Objective. The MEF CoS IA defines different PTs.	MEF 23.1 [18]
<b>PTP</b>	Precision Time Protocol	IEEE 1588 <sup>TM</sup> -2008 [28]
<b>QL</b>	Quality Level of clock used in Synchronous Ethernet	ITU-T G.8264 [34]
<b>RAN</b>	Radio Access Network	3GPP TS 36.300 [74]
<b>RAN BS</b>	RAN Base Station	This IA
<b>RAN CE</b>	RAN Customer Edge	This IA
<b>RAN NC</b>	RAN Network Controller	This IA
<b>RBS</b>	Radio Base Station defined in this IA and referred generally as Base Station in 3GPP TS 21.905	This IA
<b>RNC</b>	Radio Network Controller	3GPP TS 21.905 [57]
<b>RTP</b>	Real-time Transport Protocol	RFC 3550 [84]
<b>S-GW</b>	Serving Gateway is an LTE function and located at the Network Controller site. In this IA S-GW is one of the options for RAN NC	3GPP TS 36.300 [74]
<b>SLA</b>	Service Level Agreement	MEF 10.2 [7]

Term	Definition	Reference
SLS	Service Level Specification	MEF 10.2 [7]
SOAM	Service OAM for the ETH layer	MEF 17 [14] MEF 12.1[10]
SP	Service Provider. The organization providing Mobile Backhaul Service to a Mobile Operator.	This IA
SP EC	Ethernet Connection across the SP	MEF 12.1 [10]
SRG	Shared Risk Group. Set of NEs that are collectively impacted by a specific fault or fault type	RFC 3386 [83]
SSM	Synchronization Status Message	ITU-T G.8264 [34]
Subscriber	The organization purchasing Ethernet Service from a SP. In this IA this refers to the Mobile Operator.	MEF 10.2 [7]
TLV	Type Length Value fields in ESMC Frame	ITU-T G.8262 [33]
UNI	User Network Interface as the physical demarcation point between the responsibility of the Service Provider (MEN Operator) and the responsibility of the Subscriber (Mobile Operator)	MEF 4 [2] MEF 10.2 [7]
UNI-C	The ETH sub-layer functional components of UNI that is managed by the Subscriber (Mobile Operator), i.e., at the BS and NC sites.	MEF 4 [2] MEF 11 [9] MEF 12.1 [10]
UNI-N	The ETH sub-layer functional components of UNI that is managed by the SP (MEN Operator).	MEF 4 [2] MEF 11 [9] MEF 12.1 [10]
VLAN	Virtual LAN	MEF 10.2 [7] IEEE 802.1Q-2005 [24]
WCDMA	Wideband Code Division Multiple Access	3GPP TS 21.905[57]
WiMAX	Worldwide Interoperability for Microwave Access	WMF-T32-001 [86]

Table 1: Terminology

### 3. Introduction

The term Mobile Backhaul includes a collection of networks and network technologies, including the transport between parts of the Radio Access Network (RAN) and Core Networks. Mobile Backhaul networks have traditionally been realized using TDM and ATM technologies. Ethernet services are becoming increasingly available, even at sites with access to legacy services. This opportunity allows Mobile Operators to make the choice of which transport technology to utilize. In some cases where there is circuit based equipment that is co-located with newer Ethernet based equipment it might be suitable to use a single transport technology providing Ethernet services to lower costs. Hence, next generation mobile equipment and networks with ETH service layer functions (MEF 12.1 [10]) can support MEF Carrier Ethernet Services (MEF 6.1 [3]) using Service Attributes defined in MEF 10.2 [7], MEF 10.2.1 [8] and this IA. Carrier Ethernet services will provide the connectivity in the Mobile Backhaul network, possibly in a converged network together with traditional fixed services for business and residential services. MEF Carrier Ethernet services can be supported over any TRAN layer (MEF 4 [2]).

This Implementation Agreement uses the term Mobile Backhaul to refer to the network between the Base Station sites and the Network Controller/Gateway sites for all generation of Mobile Technologies. The NGMN Alliance [88] defines Backhaul Solution for LTE and Wimax as including the transport module in the base station (e.g. eNB in LTE or Base Station in Wimax) to the transport module in the controller (aGW). When the transport modules in the eNB or aGW

also support MEF's UNI-C functions then the NGMN Alliance's definition of Backhaul is equivalent in scope to MEF's UNI-C to UNI-C Subscriber EC (MEF 12.1 [10]) and this IA's Mobile Backhaul. In some cases MEF UNI-C might be supported on co-located platforms owned by the Mobile Operator instead of on the eNB or aGW. This case is exemplified in IP/MPLS Forum 20.0.0 [76] where, as part of the Mobile Backhaul, these are identified as a cell site gateway or a mobile aggregation site gateway. Then this IA's Mobile Backhaul scope is different from the NGMN Alliance's definition of Backhaul.

This IA defines the role of a Mobile Operator (Subscriber or Customer) as one purchasing a MEF service for Mobile Backhaul from a MEN Operator (Service Provider or Operator). These roles can also be applied for business units within the same Operator where a wireless business unit might obtain the MEF service from the transport (e.g. metro or access) business unit. The Mobile Operator is not constrained by this IA in using MEF Services with EIs only at the Base Station or Network Controller/Gateway sites. Such scenarios could involve multiple MENs, i.e., multiple network sections, to support the Mobile Backhaul between the Base Station sites and Network Controller/Gateway sites. A Mobile Operator might need MEF Services only for a portion of the Mobile Backhaul, i.e., not all the way to the RAN NC site, since they own the rest of the backhaul. In this IA the use case of multiple MENs is out of scope.

A Mobile Operator can also choose to use MEF services from a MEN Operator for some network sections of the Mobile Backhaul and use non MEF services for other network sections of the Mobile Backhaul network. This IA applies to the sections with MEF Services. If certain network sections of a Mobile Backhaul network use any non MEF Services then those sections are out of scope for this IA. When combinations of MEF and non-MEF services are used the Mobile Operator is responsible to concatenate performance across the different sections.

This document specifies the requirements for Ethernet services, EIs and Management for Mobile Backhaul. These definitions aim to support a wide range of Ethernet service based mobile network topologies.

## **4. Mobile Network Topologies**

This section illustrates different radio network topologies, how they relate to certain mobile technologies, and what to consider when defining Ethernet services for different topologies. It is not the ambition to provide a full description of each mobile technology. The reader is advised to consult the appropriate mobile standard for additional details.

Mobile technologies, such as GSM, WCDMA and CDMA, use centralized radio control functions. This means that user plane and control plane traffic is sent directly between Radio Base Stations (RBS) and the Network Controller (NC). Figure 1 below provides an example of centralized connectivity for GSM, where the Radio Base Station is called Base Transceiver Station (BTS) and the Network Controller is called Base Station Controller (BSC), and WCDMA where the Radio Base Station is called the NodeB and the Network Controller is called Radio Network Controller (RNC). The figure includes the logical interfaces<sup>1</sup> defined by 3GPP connecting the Radio Base Station and Network Controller. CDMA networks are constructed in a similar fashion.

---

<sup>1</sup> The logical interfaces between radio nodes represent relationships between those nodes; they do not represent physical connections. This implies that a logical interface can traverse several intermediary nodes.

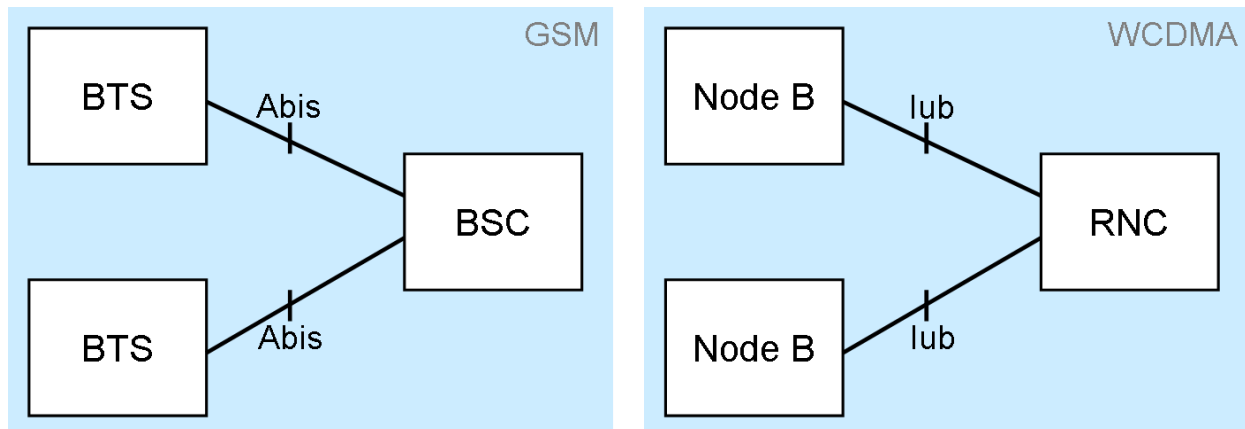

Figure 1 - Example of topology when centralized radio control functions

The evolution of mobile technologies has led to a decentralized topology as a result of some functionality previously residing in the network controller being pushed out to the radio base station. This is the case for both LTE and WiMAX. LTE is exemplified in the Figure 2 below showing logical interfaces in the wireless network topology. Notably, 3GPP Release 8 (LTE) is based on IP bearer channels like 3GPP Releases 5 to 7, but has a definitive multipoint topology as each eNB is connected to multiple functions in the Evolved Packet Core (EPC) – the direct interfaces being with other eNBs, Service Gateway (S-GW) and Mobility Management Entity (MME). These functions need not be located at the same physical site. Having the core functions geographically distributed to support S1-flex architectures (3GPP TS23.236 [62]) might require deployment of certain Ethernet services (MEF 6.1 [3]) to realize the connectivity between the RAN CEs. See also Section 7.2 for additional discussion.

The S-GW terminates the user plane traffic and the MME terminates the signaling or control plane traffic with the S1 logical Interface. There can be up to 16 S1 interfaces per eNB site as identified by the NGMN Alliance [88]. It should be noted that LTE has the concept of “pooling”, where a pool consists of one or more entities, which means that an eNB can be connected to a pool of S-GWs and MMEs (3GPP TS36.300 [74]).

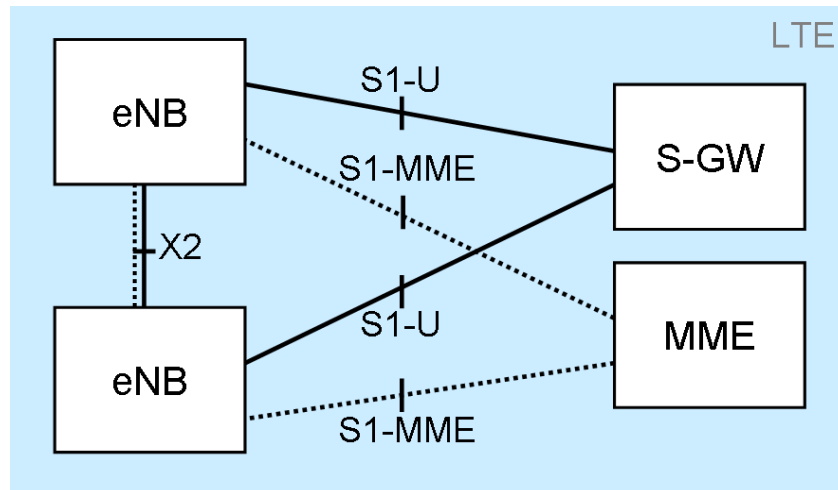

Figure 2 - Example of topology for LTE with decentralized radio control functions

Another notable difference in LTE is the logical interface between eNBs, called X2, which is not present in GSM or WCDMA. In LTE, this interface is used only for direct handovers between eNB nodes and this handover is initially independent of S-GW and MME. The destination eNB, that has the user equipment associated to it, coordinates with the S-GW/MME for shifting traffic from the original eNB (that is being sent over X2 interface during the handover) to the S1 interface for the destination eNB. Each eNB has an X2 interface relationship with a set of neighboring eNBs whereby radio handovers are possible. There can be up to 32 neighbors for each eNB [88]. Note that the RAN BS and/or NC sites can now be IP endpoints and the Network Elements at these sites can support additional functionality such as IP routing. Such capability can also be used by the Mobile Operator to constrain how the X2 connectivity across the MEN is supported. Additionally, the set of radio neighbors for a given eNB are unique and dynamic, meaning an eNB might have a different set of radio neighbors over time.

Figure 3 shows the section of WiMAX network reference model from IEEE 802.16 [27] and WMF-T32-001-R016v01 [86] relevant for this IA. The Mobile Backhaul, as defined by WiMAX forum, is from RAN BS to Access Service Network Gateway node (ASN GW). The Access Service Network (ASN) provides access to the WiMAX air interface and is controlled by the Network Access Provider (NAP). The ASN is connected to multiple core functions in the Connectivity Service Network (CSN) which provides connectivity to Internet or an Application Service Provider (ASP). The CSN is controlled by a Network Service Provider (NSP).



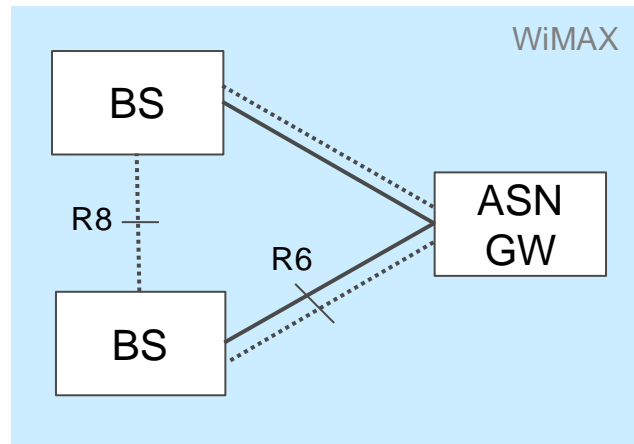

Figure 3: Example of topology for WiMAX with decentralized radio control functions

The ASN is comprised of one or more ASN-GW(s), a large number of BSs, and standard routing/switching equipment interconnecting them. The BS provides air interface coverage over one sector. The ASN-GW is a centralized controller for all the BSs in the ASN. The ASN-GW acts as a datapath anchor for the ASN and provides mobility control for all the BSs in the ASN. Interface R8 is the standard reference point between BSs in the same ASN. It is only a control channel which can be used to exchange information between BSs. The R6 standard reference point is the backhaul between the BS and the ASN-GW.

LTE and WiMAX are radio technologies based on IP bearer channels to support user IP traffic. GSM and WCDMA systems evolved from ATM and, optionally, IP bearer from 3GPP Release 5 to support user IP traffic. Note that 3GPP TS 25.933 [71] (in Section 5.8) does not make any assumption for IP based packet transport network. With MEF compliant UNI-C (MEF 11 [9] and MEF 20 [16]) Ethernet interfaces Mobile Network components in the RAN BS or RAN NC sites can use MEF Services for IP packet transport across a MEN. Mobile Network components with TDM interfaces can use MEF 3 [1] Circuit Emulation Services via a GIWF for connectivity across a MEN and can also add MEF compliant UNI-C Ethernet interfaces to offload IP data traffic. See Section 7.1 for further discussion.

Some radio deployments will utilize security mechanisms, such as IPSec (RFC2401 [80]) which is optional in 3GPP and WiMAX specifications, when the Mobile Backhaul connectivity to RAN BS is through untrusted domains. In a centralized topology the security gateway will typically be located on the same site as the network controller. The Mobile Backhaul connectivity across MEN might be mostly Point-to-Point type between a RAN BS and RAN NC site when IPSec is used for mobile technologies with a centralized Security Gateway architecture.

Operations & Maintenance traffic for Base Station management can be treated as a separate logical interface. This implies that O&M traffic can have a different logical and physical connectivity compared to control plane and user plane traffic.

## 5. Scope

### 5.1 In Scope

The following work items are within the scope of this phase of Implementation Agreement:

- Mobile Backhaul for mobile technologies referenced in standards: GSM, WCDMA, CDMA2000, WiMAX 802.16e, and LTE.
- A single MEN with External Interfaces being only UNIs for Mobile Backhaul between RAN BSs and RAN NC.
- Utilize existing MEF technical specifications with required extensions to interface and service attributes.
- Provide requirements for UNI-C and UNI-N beyond those in [11] and [16].
- Define requirements for Mobile Backhaul with Ethernet Services specified in MEF 6.1 [3].
- Provide requirements for Link OAM, Service OAM Fault Management.
- Provide requirements for Class of Service and recommend performance objectives consistent with MEF 23.1 [18], where possible.
- Specify frequency synchronization requirements where possible for packet based synchronization methods and Synchronous Ethernet.
- Functional requirements applicable to Generic Inter-Working Function interfaces.
- Specify resiliency related performance requirements for Mobile Backhaul.

### 5.2 Out of Scope

Topics that are not within the scope of this phase of Implementation Agreement include:

- Multiple MENs or External Interfaces such as ENNI are not considered in Phase 2
- Provide an architectural and functional description of the MEN internals.
- Provide a normative definition or implementation specification of the Generic Inter-working Function.
- Provide details regarding other technologies for Backhaul Networks (e.g. Legacy ATM or TDM or IP transport).
- Specify time and phase synchronization methods and requirements.
- Define synchronization architectures or promote any particular synchronization technology.
- Define mobile network evolution scenarios.

## 6. Compliance Levels

The key words "**MUST**", "**MUST NOT**", "**REQUIRED**", "**SHALL**", "**SHALL NOT**", "**SHOULD**", "**SHOULD NOT**", "**RECOMMENDED**", "**MAY**", and "**OPTIONAL**" in this document are to be interpreted as described in IETF RFC 2119 [79]. All key words must be in upper case, bold text.

Items that are **REQUIRED** (contain the words **MUST** or **MUST NOT**) will be labeled as **[Rx]** for required. Items that are **RECOMMENDED** (contain the words **SHOULD** or **SHOULD NOT**) will be labeled as **[Dx]** for desirable. Items that are **OPTIONAL** (contain the words **MAY** or **OPTIONAL**) will be labeled as **[Ox]** for optional.



## 7. Mobile Backhaul Service Model

This section includes: a description of a Mobile Backhaul reference model; definitions of reference points and functional elements; and describes use cases that reflect possible Mobile Backhaul deployments.

A Mobile Backhaul network can take on many forms depending on factors such as transport technology, mobile standard, operator preference, etc. This Implementation Agreement (IA) focuses on the Mobile Backhaul network between Radio Base Station sites and Radio Network Controller/Gateway sites. The Mobile Backhaul service is between demarcations separating the responsibility of a SP or MEN Operator's domain and the Mobile Operator's domain. This is the MEN supporting MEF 6.1 Services [3] between UNI reference points. Figure 4 describes a service reference model where the Mobile Backhaul service across a single domain (i.e., single Service Provider) is providing connectivity to Mobile Network Nodes, i.e., RAN CEs.

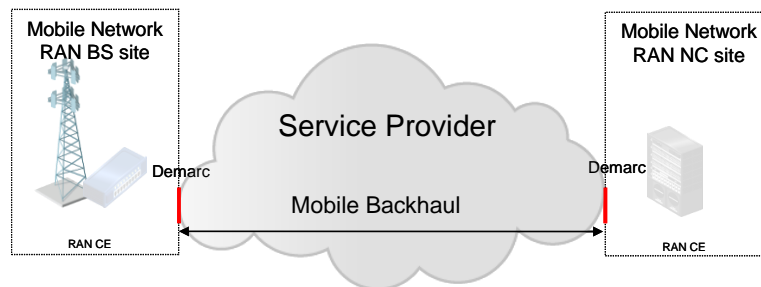

Figure 4 : Single Domain Mobile Backhaul Reference Model

RAN CE is a generic term that identifies a mobile network node or site, such as a RAN Network Controller (RAN NC) or a RAN Base Station (RAN BS). A RAN NC might be a single network controller/gateway or a site composed of several network controllers including: OSS, WCDMA Radio Network Controller, or synchronization server. A RAN BS site can also be a single base station or a collection of several base stations of the same or different technologies. For example, a RAN BS site can contain a GSM and WCDMA radio base station.

A RAN CE might have legacy TDM interfaces. Hence, a Mobile Operator can use a TDM demarcation to obtain CES (MEF 3 [1] and MEF 8 [5]) for emulation of TDM Services across the Service Provider's MEN. Alternatively, with an Ethernet interface supporting MEF ETH layer functions (MEF 12.1 [10]) the Mobile Operator can obtain Ethernet Services (MEF 6.1 [3]) from the SP. The EVC (MEF 10.2 [7]) is the service construct offered by the MEN in support of a MEF service. The technical definition of a service, is in terms of what is seen by each CE (MEF 10.2 [7]). This includes the UNI which is the demarcation point between the responsibility of the MEN Operator and the responsibility of the Mobile Operator.

Additional use cases such as multiple MEN domains, use of other EIs, and MEF services for portions of Mobile Backhaul are possible but are not considered in this Phase 2 work.

## 7.1 Service Model Use Cases

Based on the basic reference model above in Figure 4 it is possible to derive the use cases below, where each use case presents a possible deployment scenario using MEF services. Although the use cases are not exhaustive of all possible deployment scenarios, they will be the foundation of this IA. The focus of this IA is to recommend capabilities at the UNI and applicable MEF Services in support of Mobile Backhaul; referencing MEF specifications, and specifying extensions when necessary. While the use cases describe an evolution of the basic service model shown in Figure 4 it is possible for the legacy and MEN domains to be different SPs.

### 7.1.1 Use Case 1: RAN CE with TDM Demarcation

Use cases 1a and 1b are example deployments where the RAN BS and RAN NC cannot be directly connected to a MEF Ethernet UNI (MEF 11 [9]) because they have non-Ethernet based service interfaces, such as ATM or TDM. The TDM demarcation at the RAN BS and NC sites is the scope for Mobile Backhaul as illustrated in Figure 5 and Figure 6. Use cases 1a and 1b require a GIWF, which in turn is connected to the UNI for a MEF 6.1 Service [3] across the MEN domain. The GIWF is described in Generic Inter-working Function (Informative).

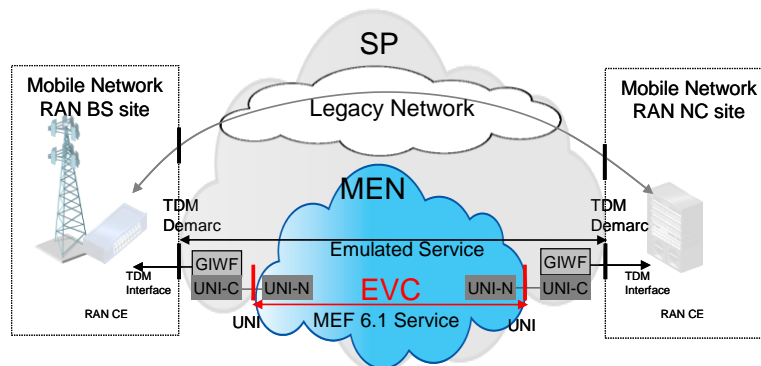

Figure 5: Use Case 1a – Low Priority traffic using CES across MEN

Use case 1a, shown in Figure 5, illustrates a split service scenario where there are two parallel Mobile Backhaul services, across a legacy (e.g. TDM) network and across a MEN, that transport different types of mobile traffic. As shown in Figure 4, SP owns the GIWF function and, for example, a CES across the MEN domain, using the framework defined in MEF 3 [1], is offered to the Mobile Operator. This might be appropriate in cases where a Mobile Operator wants to offload low priority but high bandwidth traffic from the legacy network to the MEN in order to scale with network demand. How and where traffic is split and sent over the legacy network is out of scope for this IA.

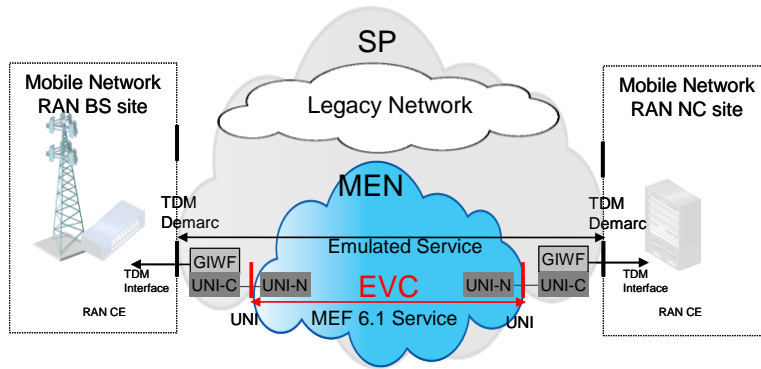

Figure 6: Use Case 1b – All traffic with CES across MEN

Use case 1b, shown in Figure 6, depicts a deployment scenario where the RAN CE with TDM interface is connected to the SP at a TDM demarcation but all traffic from the RAN CE now uses CES across the MEN with Ethernet services.

7.1.1.1 **Specific Requirements related to Use Case 1:**

- Synchronization with TDM demarcation: See Interface requirements in Section 12.2.3
- CoS & CPO: See Class of Service in Section 11.5

7.1.2 **Use Case 2: RAN CE with Ethernet (MEF UNI) Demarcation**

The last two use cases illustrate RAN CE equipment that can be connected directly to the MEN with a MEF compliant UNI-C Ethernet interface eliminating the need for a GIWF. Similar to use case 1a, use case 2a, as shown in Figure 7, uses MEF 6.1 services [3] to offload certain traffic, such as low priority high bandwidth traffic, from the legacy network. How the RAN CE transports real-time and synchronization traffic via the legacy network is out of scope for this implementation agreement.

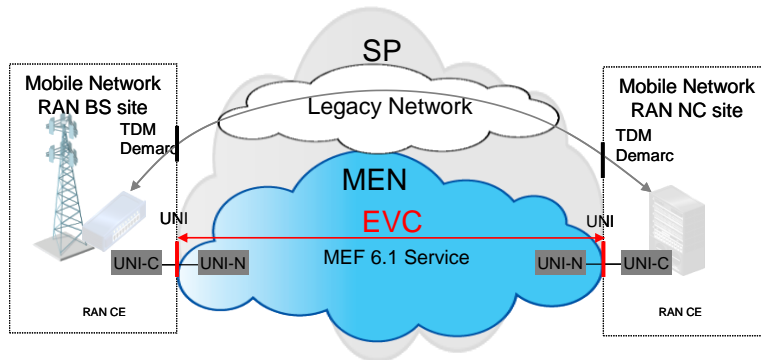

Figure 7: Use Case 2a – Low priority traffic with MEF 6.1 Service across MEN

It should be considered that in use case 1a and 2a, frequency synchronization is typically recovered from the legacy network, e.g.; from TDM physical layer. This implies that for use case 1a and 2a synchronization with Physical Layer (Synchronous Ethernet) or Packet based methods are not required to be provided by MEN.

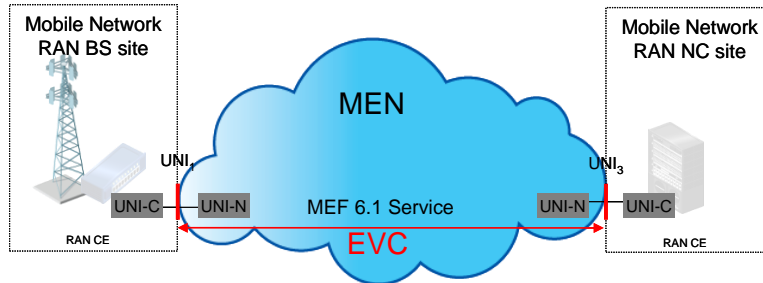

Figure 8: Use Case 2b – All traffic with MEF 6.1 Service across MEN

Lastly, use case 2b, shown in Figure 8, is the case where all traffic uses MEF 6.1 Ethernet services [3] across the MEN. How the Ethernet services are realized can vary depending on the mobile technology that is deployed, vendor equipment, operator requirements, and the type of services offered by the MEN.

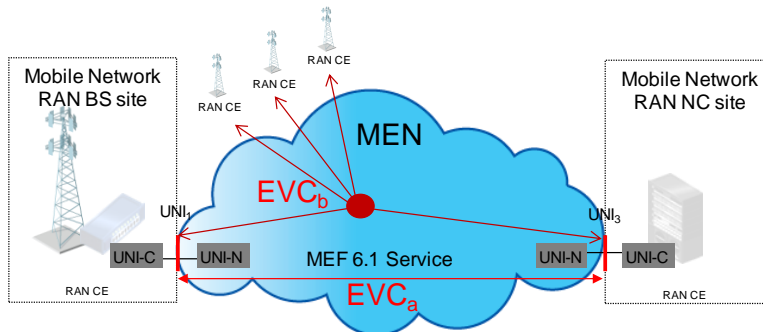

Figure 9: MEF 6.1 Service for connectivity between any RAN CEs

In Figure 9, Mobile Backhaul is shown with different EVC types (MEF 10.2 [7]). Either Point-to-Point (e.g. EVC<sub>a</sub>) or Multipoint (EVC<sub>b</sub>) can be used to support the logical interfaces for user and signaling plane between RAN CEs. Use of different EVC types is discussed in Section 7.2 (Normative) and in Mobile Backhaul Services (Informative).

### 7.1.3 Common Requirements related to Use Cases 1 and 2

- MEF 6.1 Services: See Section 7.2
- OAM for FM and PM: See Section 8 and 10.1
- UNI: See Section 10

- Performance attributes and objectives: See Sections 9, and 11
- EVC: See Section 11
- Synchronization: See Sections 10.4 and 12

## 7.2 Applying MEF Service Definitions to Mobile Backhaul

This section specifies the Mobile Backhaul Ethernet services. In addition to the baseline definition of MEF Services in MEF 6.1 [3], using service attributes defined in MEF 10.2 [7], this IA has specified requirements using attributes defined in this IA as well as in MEF 10.2.1 [8].

**[R1]** The Mobile Backhaul Ethernet service between MEF compliant UNIs **MUST** comply with one of the following VLAN based Ethernet service definitions (MEF 6.1 [3]) in terms of the service attributes for UNI and EVC, in addition to those specified in this IA (see also Section 10.5.1 and Section 11.6.1):

1. Ethernet Virtual Private Line Service (EVPL)
2. Ethernet Virtual Private LAN service (EVP-LAN)

**[D1]** The Mobile Backhaul Ethernet service between MEF compliant UNIs **SHOULD** comply with the following VLAN based Ethernet service definition (MEF 6.1 [3]) in terms of the service attributes for UNI and EVC, in addition to those specified in this IA (see also Section 10.5.1 and Section 11.6.1):

1. Ethernet Virtual Private Tree Service (EVP-Tree)

A Mobile Operator is more likely to use VLAN based services (EVPL, EVP-LAN, EVP-Tree) given the scalability of supporting many RAN BS sites with each UNI interface at a RAN NC site. Further, such VLAN based services also allow bandwidth profiles to be tailored to the needs of a RAN BS. For example, a smaller subset of RAN BSs might have higher user density with more traffic while most other RAN BSs might not. A Port based service such as EP-LAN, for example, is constrained to applying one bandwidth profile per CoS ID for traffic to all RAN BSs UNIs in the EVC. A Port based service also dedicates a RAN NC UNI resulting in inefficient use of the port. However, port based services could be applicable when a Mobile Operator uses each UNI port at RAN NC to be associated with UNIs at a limited number of RAN BSs so a failure of the UNI at RAN NC or in the MEN does not impact all RAN BSs.

**[D2]** The Mobile Backhaul Ethernet service between MEF compliant UNIs **SHOULD** comply with the following Port based Ethernet service definition (MEF 6.1 [3]) in terms of the service attributes for UNI and EVC in addition to those specified in this IA (see also Section 10.5.2 and Section 11.6.2):

1. Ethernet Private LAN Service (EP-LAN)

**[O1]** The Mobile Backhaul Ethernet service between MEF compliant UNIs **MAY** comply with one of the following Port based Ethernet service definitions (MEF 6.1 [3]) in terms of the service attributes for UNI and EVC in addition to those specified in this IA (see also Section 10.5.2 and Section 11.6.2):

1. Ethernet Private Line Service (EPL)
2. Ethernet Private Tree Service (EP-Tree)

See Section 10.5 for the UNI Service Attributes and Section 11.6 for EVC Service Attributes from MEF 6.1 [3] as well as constraints, if any, as defined in this IA.

Compliance for support of some of the attributes for E-Line and E-LAN services is validated with ATS for Ethernet Services at the UNI (MEF 9 [6]) and performance attributes for Traffic Management (MEF 14 [12]). However, these ATSS do not include updated attributes and definitions specified in MEF 10.2 [7], MEF 10.2.1 [8] and this IA in addition to E-Tree services in MEF 6.1 [3].

In LTE and WiMAX, E-Line is more likely to be used when IPSec mechanisms are used to transit through untrusted MEN domains with centralized Security Gateways. E-Line can be used to support both S1 (or Wimax R6) and X2 (or Wimax R8) traffic. For X2 or R8 interface, E-Tree with root UNI at RAN NC site is also a possibility. In these cases it is assumed that a switching or routing function exists at the RAN NC of the Mobile Operator domain to forward X2 or R8 traffic to destination RAN BS sites.

Alternatively, an E-LAN service can be used to support traffic between RAN BSs as well as to RAN NC. Such a multipoint service can provide the necessary connectivity between RAN CEs in the same IP subnet.

The RAN NC itself can be viewed as an aggregation facility in that it can support service connectivity to large numbers of RAN BS sites. The NGMN Alliance [88] suggests example dimensioning and scalability with 1000 eNB sites per aGW. So, a RAN NC site might support up to 16000 S1 Interfaces with 16 S1 interfaces per eNB. Often the RAN NC is in a single location that gives mobile providers several options to connect RAN BSs with the RAN NC, including: a port-based implementation with one UNI per RAN BS, or a VLAN-based implementation with EVCs from different RAN BSs service multiplexed at one or more RAN NC UNIs. When several EVCs are multiplexed on a single UNI, there is a risk of a single point of failure, and therefore an appropriate EVC resiliency performance should be considered. A similar approach might also be adopted at other UNIs in the Mobile Backhaul network, for example at RAN BS sites with several base stations. Refer to Section 9 for resiliency performance attributes, Section 10.3 for UNI Resiliency, and Section 11.4.2 and 11.4.3 for Resiliency performance.

### **7.2.1 Ethernet Private Line Service**

The Ethernet Private Line (EPL) services (MEF 6.1 [3]) are port based services with exactly 2 UNIs in an EVC. It is equivalent to the leased line services used for Mobile Backhaul service between the RAN NC and RAN BS. All untagged, priority tagged and tagged Service Frames are mapped to 1 EVC at the UNI. The EPL service might be preferred in cases where there is a desire for a 1:1 port level correspondence between the RAN NC and each RAN BS UNI as shown in Figure 10. Port based EPL services with dedicated UNI ports at RAN NC for every BS is not a scalable model. VLAN based EVPL as described in Section 7.2.2 is preferred.



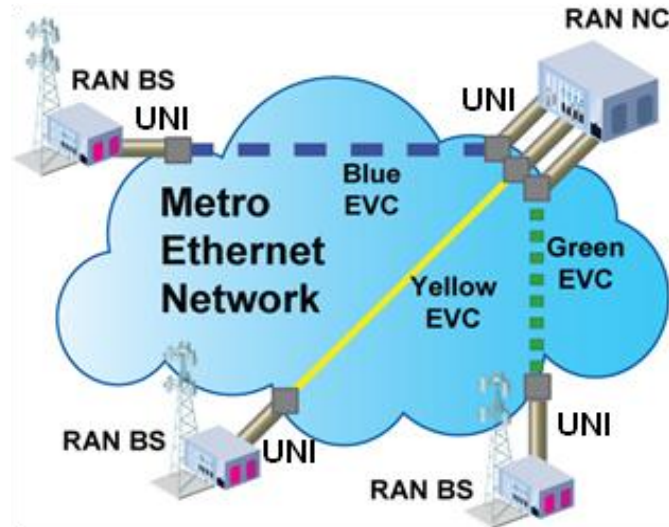

Figure 10: Ethernet Private Line (EPL) Service

### 7.2.2 Ethernet Virtual Private Line Service

The Ethernet Virtual Private Line (EVPL) service (MEF 6.1 [3]) for Mobile Backhaul is VLAN based services with exactly 2 UNIs in each EVC and is used to access multiple RAN sites with Service Multiplexing (>1 EVC) at the RAN NC UNI. This allows efficient use of the RAN NC UNI, as illustrated in Figure 11. The CE-VLAN ID to EVC map and Bundling service attributes (MEF 10.2 [7]) are used to identify the set of CE-VLANs, including untagged and priority tagged Service Frames, which map to specific EVCs at the UNI. At the RAN NC UNI, for example, if there is an EVC per RAN BS site then there is an upper bound of 4095 RAN BSs, assuming 1 CE-VLAN ID per RAN BS site.

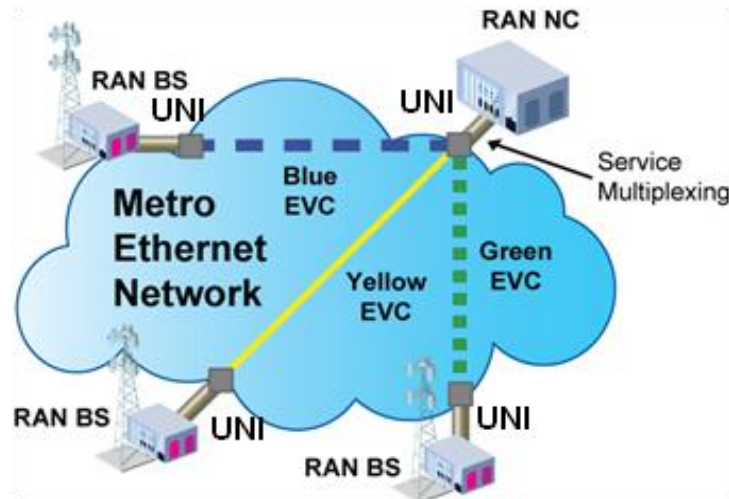

Figure 11: Ethernet Virtual Private Line (EVPL) Service

### 7.2.3 Ethernet Private LAN Service

Mobile Operators, with multiple RAN NC sites or deployments where inter RAN BS communication is permitted, might want to interconnect them so all sites appear to be on the same Local Area Network (LAN). The Ethernet Private LAN (EP-LAN) service (MEF 6.1 [3]) as shown in Figure 12, provides a port based service with 2 or more UNIs in the EVC.

The EP-LAN service is defined to provide All to One bundling at each UNI, CE-VLAN ID preservation, CE-VLAN CoS preservation, and tunneling of key Layer 2 Control Protocols. A key advantage of this approach is that if the Mobile Operator has outsourced its backhaul network to a service provider, e.g., transport/transmission network organization, the Mobile Operator can configure CE-VLANs at the RAN NCs and the RAN BSs without any need to coordinate with the Service Provider.

In LTE or WiMAX deployments, the EP-LAN service can be used to connect RAN BS sites containing eNBs or WiMAX BSs on the same IP subnet to realize the X2 or R8 interface respectively. Furthermore, EP-LAN services provide efficient connectivity between eNBs and pooled gateway nodes, such as S-GW and MME that might reside on different RAN NC sites.



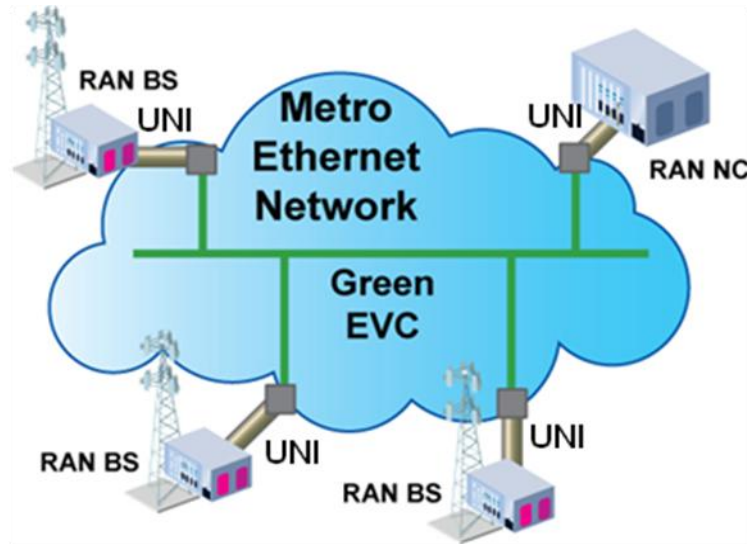

Figure 12: Ethernet Private LAN (EP-LAN) Service

#### 7.2.4 Ethernet Virtual Private LAN Service

Some Mobile Operators commonly desire an E-LAN service type (MEF 6.1 [3]) to connect their UNIs in a MEN, while at the same time accessing other services from one or more of those UNIs. An example of such a UNI is a Mobile Operator site that has co-location of RAN BS of different technologies, e.g. legacy GSM and WiMAX. Each technology can have a specific EVC assigned to transport Mobile Backhaul traffic and different UNI peers. The Ethernet Virtual Private LAN (EVP-LAN) service is as shown in Figure 13.

The EVP-LAN service allows less transparency with respect to CE-VLAN ID and L2CP processing than the EP-LAN service. As example, different CE-VLAN ID sets can be mapped to the different EVCs at the UNI with Service Multiplexing. The CE-VLAN to EVC map and Bundling service attributes (MEF 10.2 [7]) are used at the UNIs. Operators can also configure required L2CP processing as specified in MEF 6.1 [3]. As such, CE-VLAN ID preservation, CE-VLAN CoS preservation, and tunneling of certain Layer 2 Control Protocols can be constrained as defined in MEF 6.1 [3].

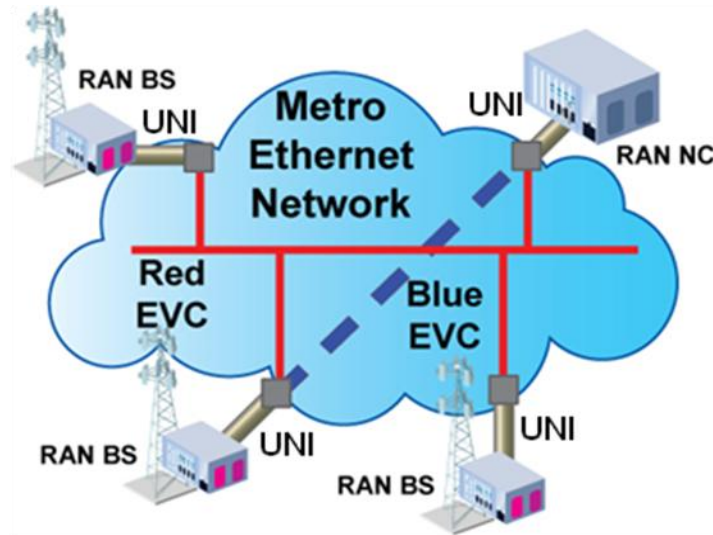

Figure 13: Ethernet Virtual Private LAN (EVP-LAN) Service

### 7.2.5 Ethernet Private Tree Service

Mobile Operators with multiple sites might use an EP-TREE (MEF 6.1 [3]) with 2 or more UNIs in the EVC. This type of service forces a leaf UNI to send and receive Service Frames to and from root UNIs and not to and from other leaf UNIs in the EVC. Such a configuration is useful when all traffic needs to go through 1 or more centralized sites designated as roots and all the remaining sites designated as leaves.

Traditionally in Mobile Backhaul the RAN BS sites only need to exchange Service Frames with the RAN NC site(s) and not with other RAN BSs. This behavior is possible in an Ethernet Private Tree (EP-Tree) service, where the RAN NC site(s) would be root(s) and the RAN BS sites would be leaves as shown in Figure 14.

The EP-Tree service is defined to provide All to One bundling, CE-VLAN ID preservation, CE-VLAN CoS preservation, and tunneling of key Layer 2 Control Protocols. A key advantage of this approach is that the Mobile Operator can configure VLANs across the sites without any need to coordinate with the Service Provider.

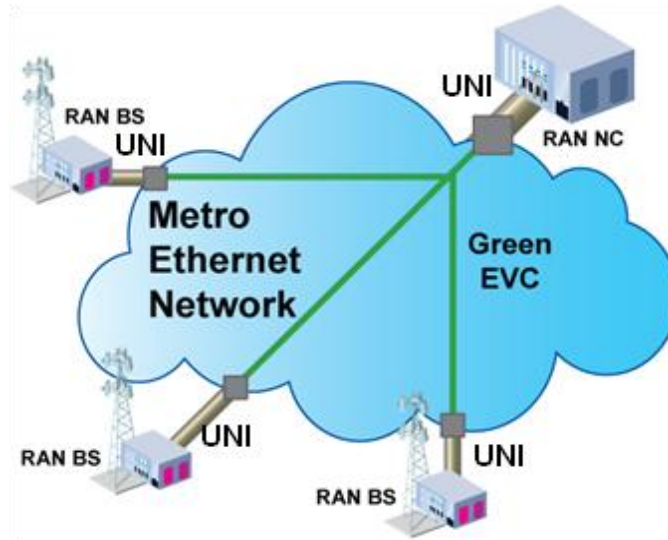

Figure 14: Ethernet Private Tree (EP-Tree) Service

### 7.2.6 Ethernet Virtual Private Tree Service

Some Mobile Operators desire to keep the root-leaf relationship between RAN NC and RAN BS sites, but also want to have Service Multiplexing with >1 EVC at one or more of the interconnected UNIs. For such cases, the EVP-Tree service (MEF 6.1 [3]) is used.

The CE-VLAN to EVC map and Bundling service attributes (MEF 10.2 [7]) are used at the UNIs. As such, CE-VLAN ID preservation, CE-VLAN Cos preservation, and tunneling of certain Layer 2 Control Protocols might not be provided. Figure 15 shows the basic structure of EVP-Tree service. As an example, the EVP-Tree service can be used to transport mobile voice and data traffic while the EVP-LAN service offers an inter-site connection for node and site management.

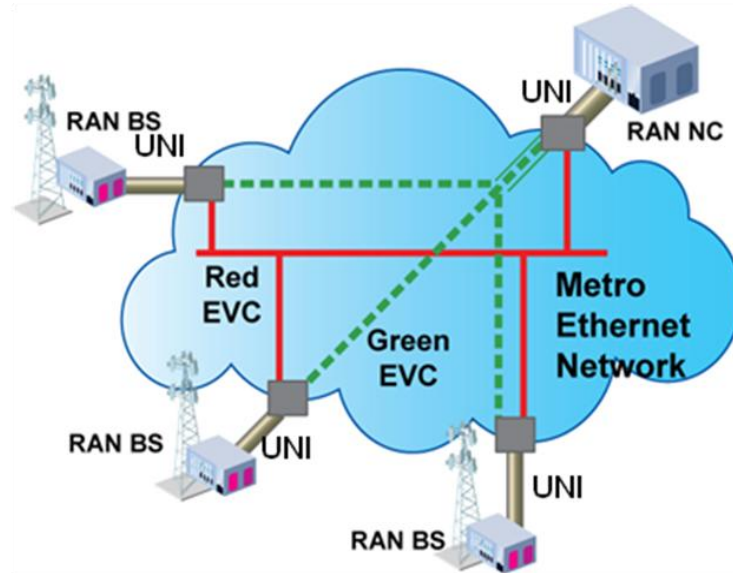

Figure 15: Ethernet Virtual Private Tree (EVP-Tree) Service

## 8. Management Model for Mobile Backhaul Service

This section specifies the OAM model for FM and PM for a MBH service across a single MEN domain. In addition to Service OAM (MEF 17[14]), Link OAM (MEF 20 [16]) is also specified for use across a UNI.

### 8.1 Ethernet OAM

Ethernet OAM is a term used in this IA to collectively refer to Link OAM (MEF 20 [16]) and SOAM (MEF 17 [14] and MEF 30[22]). Ethernet OAM requirements are not specified in any current mobile standards from 3GPP, 3GPP2 or IEEE 802.16. RAN CEs with legacy TDM or ATM interfaces for Mobile Backhaul implemented SONET or SDH and also ATM OAM. RAN CEs with Ethernet interfaces for Mobile Backhaul can implement Ethernet OAM.

Ethernet OAM is desirable for fault management, connectivity management, and performance monitoring of the Mobile Backhaul Service as well as the UNI. For example, a UNI Type 2 interface (MEF 20 [16]) with support for E-LMI (MEF 16 [13]) could be used by a UNI-N to notify the UNI-C at RAN CE about EVC state. E-LMI could also help in automating the configuration of CE-VLAN IDs to use by the UNI-C in RAN CE. The UNI-C with SOAM capability could measure performance using the Subscriber MEG.

Link OAM and Service OAM are OAM mechanisms with similar fault management capabilities, but operate on different network layers. Link OAM monitors the TRAN Layer (MEF 12.1 [10]) by running Link OAM frames between the UNI-C and UNI-N. Service OAM, on the other hand, monitors the ETH Layer (Ethernet Services Layer in MEF 12.1 [10]) and can span one or multiple Ethernet Links. Service OAM can also be configured to monitor the link between the UNI-C and UNI-N. Typically either Link OAM or Service OAM are used to monitor the UNI, but not both, as this can potentially introduce contradictory measurement results.

**[D3]** Link OAM as per MEF 20 [16] **SHOULD** be supported in a MEF compliant UNI.

See Section 10.1 for UNI Types. UNI Type 2.1 has Link OAM as a ‘MAY’ in R5 of MEF 20 [16]. In this IA [D3] has elevated this to a ‘SHOULD’. Also, Link OAM is recommended to be supported for UNI Type 1 as well.

## 8.2 Service OAM

The Mobile Backhaul network’s FM and PM reference model for SOAM is illustrated in Figure 16 below. The figure shows the reference model for Service and SOAM for FM as well as PM.

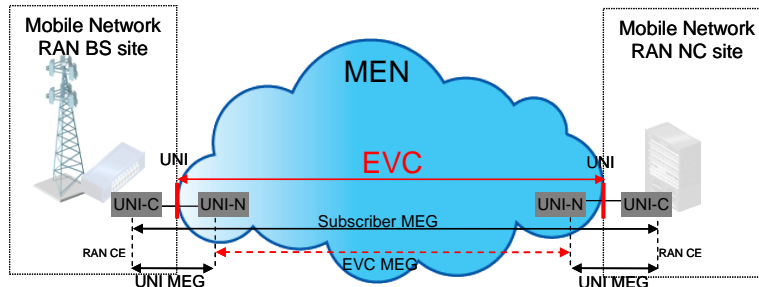

Figure 16: FM and PM Reference Model for Use Case 2

Figure 16 shows a Point-to-Point EVC type between RAN BS and RAN NC sites. However, this FM and PM model also applies to other EVC types and for EVCs between RAN BS sites only or between RAN NC sites only. SOAM (MEF 17 [14] and MEF 30 [22]) is used on the different service components (UNI, EVC) by Mobile Operator as well as MEN Operator. For an EVC that has N UNIs in the EVC there are many ordered pairs and a subset of ordered UNI pairs (MEF 10.2 [7], MEF 10.2.1 [8]) might have SLS objectives. So, FM and PM might be performed on that subset.

MEF 17 [14] and MEF 30 [22] specify the MEGs to use for FM and PM. A MEN Operator can use all or some of the MEGs for FM and PM. For example, the TEST MEG might be used at the time of initial service activation of the Mobile Backhaul Service. Three MEGs for which FM and PM requirements can be applicable in Mobile Backhaul are illustrated in the figure. These are defined in MEF 17 [14] and MEF 30 [22]:

- UNI MEG (between UNI-C and UNI-N),
- EVC MEG (between peer UNI-Ns), and
- Subscriber MEG (between peer UNI-Cs, i.e., End-to-End Flow or Subscriber EC as defined in MEF 12.1 [10])

These are described in MEF 30 [22] which has incorporated the requirements of MEF 6.1 [3] and MEF 20 [16]. A UNI type 1 implementation might have the capability to support SOAM although not specified in MEF 13 [11]. However, a UNI Type 2 implementation will have capability to support SOAM per MEF 20 [16].

**[R2]** If the Mobile Operator (Subscriber of Mobile Backhaul service) uses SOAM to monitor service then Subscriber MEG, as defined in MEF 30 [22], **MUST** be used.

A Mobile Operator could use the Subscriber MEG for fault management and to measure performance metrics such as FLR for the Subscriber EC between RAN CEs. This can help determine the condition of the connectivity among peer UNI-Cs. The RAN CE can use this

information to perform transport resource management for user and signaling traffic as suggested in Section 4.3.3 of the NGMN Alliance specification [88]. The specific methods for transport resource management by a RAN CE are outside the scope of this IA.

**[R3]** If the MEN operator uses SOAM at the service level then the EVC, SP or Operator MEG, as defined in MEF 30 [22], **MUST** be used.

The UNI MEG is for monitoring the status of the physical connectivity between the RAN CE instantiating the UNI-C functions and the MEN NE instantiating the UNI-N functions.

**[R4]** If SOAM is used to monitor the UNI then the UNI MEG, as defined in MEF 30 [22], **MUST** be used.

Furthermore, with UNI Type 2 [16] the RAN CE can be notified of EVC status using E-LMI protocol (MEF 16 [13]) so the transport modules in the RAN CEs (eNB and aGW) can apply necessary transport resource management as suggested in Section 4.3.3 of the NGMN Alliance specification [88]. The specific methods for transport resource management by a RAN CE are outside the scope of this IA.

The MEPs and MIPs for these MEGs are the provisioned OAM reference and measurement points to initiate and terminate OAM frames, as appropriate, for FM and PM (MEF 17 [14], MEF 30[22], MEF 12.1 [10]). As an example, the PM metrics for the EVC are defined UNI to UNI (MEF 10.2 [7], MEF 10.2.1 [8]). To perform PM measurements for the EVC, the MEN operator will need to provision the MEPs for the EVC MEG at the NEs supporting UNI-N functions close to the UNI demarcation point. Methods describing how to perform PM measurements are out of scope for this IA.

## 9. Resiliency related Performance Attributes for EVC

Service Resiliency performance attributes allow a MEN Operator to offer MEF Services that are resilient to failures that affect UNI or EVC with limits on the duration of short term disruptions and to apply constraints like diversity. Service Resiliency performance depends on the capabilities of the components of the Service: EI (UNI) and the EVC that associates the EIs.

The Mobile Operator can request the MEN operator to support appropriate performance attributes in the SLS for the EVC, i.e., per CoS ID (MEF 10.2 [7], MEF 10.2.1 [8]) in addition to choosing a UNI Type for implementation of the UNI. The Service model along with FM and PM reference model shown in Figure 16 is used in defining resiliency requirements for the UNI and the EVC in the context of a Mobile Backhaul Service.

In use cases such as LTE or WiMAX, the EVC type can be different, as discussed in Section 7.2, for X2 and/or S1, or WiMAX R6 and R8, and there might be different performance considerations for X2/R8 or S1/R6 interfaces. S1-flex architecture, discussed in Section 4, could be designed with two RAN NC UNIs in one E-LAN or E-Tree service. A SLS could then be defined where failure of one RAN NC UNI would still allow the EVC to be in Available state. In addition, there might be a need for the MEN to notify RAN CEs of the status of the EVC if the EVC is partially Available (e.g. one RAN NC UNI in the EVC is in failure state).



UNI Resiliency requirements are in Section 10.3 and EVC Resiliency performance in terms of PM attributes is in Section 11.4.2 and 11.4.3.

## 9.1 Short Term Disruptions

The resiliency performance attributes defined in [8] are High Loss Interval (HLI) and Consecutive High Loss Intervals (CHLI) in addition to Availability objective for a given CoS Frame Set. HLI and CHLI can be important to Mobile Operators since short term disruption in the MEN can result in much longer term disruption in the Mobile services (e.g., loss of required signaling and control can cause re-initialization). The NGMN Alliance identifies a Service Continuity time (in Section 5.2.1) [88] for a mobile user equipment to disconnect and specifies a range of 500ms-2s. Since this includes both the radio link to user and Mobile Backhaul segments the short term disruptions in the MEN, if any, might need to be smaller than the range mentioned in the NGMN Alliance specification [88]. The duration of any disruption as seen by a RAN CE can be smaller than the CHLI for a given CoS Name if the MEN domain or the RAN CEs have mechanisms to recover faster from such disruptions. Such mechanisms can help in achieving a target of 50ms-250ms switching time to an alternate aGW (RAN NC) site as recommended in Section 5.2.1 of the NGMN Alliance specification [88] since 3GPP specifications allow for S1-flex (3GPP 23.236 [62]).

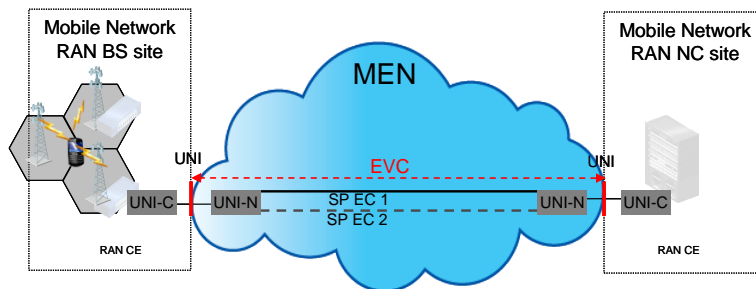

Figure 17: Association of EVC to two SP ECs for improved resiliency

Availability objective for the EVC can be used by a MEN Operator to design the required number of SP ECs [10] to which an EVC can be associated in the MEN. For example, if an EVC is requested with lower Availability, such as for a MEF CoS Label L in MEF 23.1 [18], then the MEN Operator can associate the EVC with one unprotected SP EC. A high frame loss event of the SP EC or failure of EIs in the EVC for  $\{n \times \Delta t\}$  intervals or more (MEF 10.2 [7], MEF 10.2.1 [8]) will transition the EVC to Unavailable state until such time the fault condition is repaired. On the other hand when higher Availability is required then the EVC can be associated with 2 or more SP ECs so as to maintain service performance by choosing one of the working SP EC, with none or minimal disruptions to the service, during fault conditions in the MEN.

With HLI and CHLI attributes the MEN operator can also quantify the number of such short term disruptions, if any, to the service. It is also possible to evaluate the duration of disruptions using HLI or CHLI information in a given measurement period (MEF 10.2.1 [8]). Such objectives on HLI or CHLI counts can be included in the SLS for the EVC. For example, a Mobile Operator could have an objective of  $\leq 10$  per month for CHLI events. A p-CHLI event

might have been defined with  $p=2$  for 2 or more consecutive high loss intervals but  $<n$  consecutive time intervals used to determine transition from Availability to Unavailability (MEF 10.2.1 [8]). Thus, a 3 second duration of disruption would result in one 2-CHLI and count toward an objective of  $\leq 10$  per month. The Operator might need to choose both an Availability  $\Delta t$  interval and  $flr$  threshold combination to determine a HLI that is of the order of duration of disruption. This will allow correlating the count of HLI or CHLI events with the number of disruption events, if any, during the measurement period.

A MEN domain might have mechanisms to recover from high loss events. If there is sufficient frame loss during any failure recovery processes at the service level (eg. CoS Frame Set) then the time intervals will register as high loss intervals (or even as a CHLI). Such processes might include selection of an alternate EC and updating resource allocation in NEs including forwarding rules along the failed and alternate paths. The mechanisms might be in the ETH layer to select an alternate EC or in the TRAN layer (MEF 4 [2]) and are out of scope for this IA.

## 9.2 Diversity

As discussed in Section 9.1 a MEN Operator can maintain service performance for an EVC, during fault conditions in the MEN, using multiple ETH layer connections or TRAN layer connections in the MEN. The Availability performance of the EVC is improved if there is at least one connection, within the MEN, that is fault free to support the EVC. This is much more likely if the connections supporting an EVC have diversity constraint with different Shared Risk Groups (SRGs). Shared Risk Group (SRG) is a set of NEs that are collectively impacted by a specific fault or fault type (in Section 2.2.2), RFC 3386 [83]. In this IA this is referred to as facility SRG where facility refers to NEs owned by an Operator and can also include Fiber links. In this case the MEN Operator is responsible to minimize the short term disruptions for the EVC with mechanisms to recover from high loss events by selecting a diverse connection. The duration of such short term disruptions, if any, is reported with HLI, CHLI and A in the SLS. This is categorized as MEN Resiliency in this IA.

A MEN operator can likewise ensure diversity between EVCs by using different SRGs such that at least 1 EVC is not impacted by a specific fault or fault type. The MEN Operator will have an SLS with resiliency performance attributes, i.e., HLI, CHLI and A, to report the duration of short term disruptions in each EVC. The MEN Operator is not required but can choose to use additional mechanisms within the MEN to minimize the short term disruptions for each EVC. This is categorized as RAN Resiliency in this IA.

A Mobile Operator typically has certain performance targets that it measures for its user equipment, i.e., equipment internal to Mobile Operator network. One of these can be resiliency and this is often a function of the handoff between the multiple RAN BS that the user equipment has access to. A Mobile Operator might use the fact that there are multiple RAN BS available for user equipment to stay connected – this is categorized as Radio Resiliency in this IA. While the details of Radio Resiliency are out of scope for this IA, the Mobile Operator might leverage features of MEN Resiliency or RAN Resiliency to improve its overall Radio Resiliency performance.



### 9.2.1 ETH-layer Diversity

The Ethernet Services layer, or ETH Layer, refers to the Ethernet networking layer defined by the MEF to specify Ethernet oriented connectivity services (MEF 12.1 [10]). MEF services have PM defined for a set,  $S$ , of ordered UNI pairs (MEF 10.2 [7], MEF 10.2.1 [8]) and objective for the Set  $S$  (e.g.,  $A_T^S$  for Availability) is specified for an interval  $T$  (e.g., 30 days). Such a set might contain all or some subset of ordered UNI pairs in the EVC. For an E-Line (EPL or EVPL) there are two ordered UNI pairs (i.e., both directions of an EVC). In most use cases an operator might choose to have both ordered UNI pairs in one set and so the SLS is then specified for that one set.

For an E-LAN or E-Tree there are many ordered UNI pairs which can be grouped in one set or multiple sets of ordered UNI pairs. If all ordered UNI pairs are in one set then a fault might impact all ordered UNI pairs in the set and the EVC will then transition to Unavailable state. The fault can be at a UNI or anywhere in the MEN. With multiple sets a MEN Operator has SLS for each set but can additionally specify that the EVC is considered to be in Available state when at least one set is in fault free condition. A typical example in Mobile Backhaul service would be where there are 2 RAN NC UNIs in the EVC (e.g. dual rooted E-Tree) but now each RAN NC UNI is in a different set of ordered UNI pairs. This allows the RAN BS sites to maintain connectivity with at least one RAN NC site. The Mobile Backhaul service is more likely to have at least one set to be in fault free condition if the sets are diverse.

Diversity can be a constraint between sets of a given EVC or sets across two or more EVCs. However, each set has ordered UNI pairs with UNIs in the EVC. The Set  $S$ , of ordered UNI pairs  $\langle i,j \rangle$  with  $\{m\}$  UNIs in the EVC, is defined as the ETH-layer SRG (ESRG) attribute where

$$S = \subseteq \{ \langle i, j \rangle \mid i = 1, 2, \dots, m \ \& \ j = 1, 2, \dots, m \ \text{with} \ i \neq j \} \quad \text{Equation 1}$$

**[R5]** If diversity in the ETH layer is required then the requirements [R6] to [R9] **MUST** apply.

**[O2]** If diversity in the ETH layer is required then the requirements [O3] to [O4] **MAY** apply.

TRAN layer (MEF 12.1 [10]) diversity is forced by the need for ETH layer diversity, i.e., If two sets are to be diverse in each TRAN layer link or NE then the diversity test is done in each such TRAN layer link or NE.

**[R6]** Set  $S$  **MUST** have ordered UNI pairs with UNIs in the EVC as defined in MEF 10.2 [7] and MEF 10.2.1 [8].

The set  $S$  has performance metrics defined in the SLS for a CoS Frame Set uniquely identified by the triple  $\{S, \text{CoS ID}, \text{PT}\}$  as defined in MEF 23.1 [18], i.e., set  $S$  with specific CoS ID across a specific PT. The Set  $S$  can be a subset of all ordered UNI pairs in the EVC as specified in MEF 10.2 [7] and MEF 10.2.1 [8]. See also requirements for set  $S$  in Section 11.3.

**[R7]** Set  $S$  **MUST** be selected such that the elements of the set are collectively impacted by a specific fault or fault type in the MEN.

The fault that impacts Set  $S$  will affect the performance for the CoS Frame Set identified by the triple  $\{S, \text{CoS ID}, \text{PT}\}$ .

**[R8]** The minimum number of sets  $\{S_k \mid k=1, 2, \dots\}$  to be evaluated for diversity **MUST** be 2.

[O3] The sets  $\{S_k | k=1,2,\dots\}$  **MAY** be from 1 or more EVCs.

Each set  $S_k$ , with ordered UNI pairs, now has a set of UNIs in that set:

$$U_k \subseteq \{\langle i \rangle | i=1, 2, \dots, m\} \quad \text{Equation 2}$$

A UNI Overlap attribute  $O(S)$  is defined to identify if there are any common UNIs present in the group of sets  $\{S_k | k=1,2,\dots\}$ . So, set  $S_i$  with  $U_i$  and set  $S_j$  with  $U_j$  are said to be diverse in the ETH layer if they do not have common UNIs and is mathematically represented as follows:

$$O(S) = \{U_i \cap U_j = \phi | i \neq j\} \quad \text{Equation 3}$$

The values for  $O(S)$  are ‘null’, i.e., no overlap, or ‘not null’, i.e., overlap exists between sets.

[R9] A Mobile Operator **MUST** specify the sets  $\{S_k\}$  for each CoS Frame Set identified by the triple  $\{S, \text{CoS ID}, \text{PT}\}$  for which the  $O(S)$  condition needs to be met at each facility SRG.

[R10] If two sets are to be fully diverse then  $O(S)$  **MUST** be a “null” set in each of the facility SRG in the MEN.

[O4] If two sets are to be partially diverse then  $O(S)$  **MAY** be “not null” set (i.e., can have common UNIs) in 1 or more facility SRGs in the MEN.

### 9.2.2 Availability for Diverse Group

$A_T^S$  for Availability of a set  $S$ , defined in MEF 10.2.1 [8], is specified as a percentage of time when the set  $S$  is in Available state during the interval  $T$ . The method to determine  $A_T^S$  is the same as in MEF 10.2.1[8], i.e., minimum Availability of all ordered pairs in the set.

Availability for the group of  $k$  diverse sets,  $A_T$ , is defined as a percentage of time in the interval  $T$  such that at least one set is not in Unavailable state:

$$A_T = 100 \left\{ 1 - \prod_k \left( 1 - \frac{A_T^{S_k}}{100} \right) \right\} | k = 1, 2, \dots \quad \text{Equation 4}$$

The fraction of time a set  $S$  is in Unavailable state is expressed as  $(1 - [A_T^S/100])$ . The product of the fractions of times for all  $k$  sets being Unavailable gives the fraction of time when no set is in Available state. The percentage of time when at least one set is not in Unavailable state is expressed as given in Equation 4. As example, consider when  $k=2$  (two sets). Consider that set  $S_1$  has  $A_T^S = 99.9\%$  and  $S_2$  has  $A_T^S = 99.8\%$ . Now we can determine that  $A_T = 100\{1 - [1 - 0.999] * [1 - 0.998]\} = 99.9998\%$  and thus achieving a much higher overall Availability for the Mobile Backhaul Service with diversity between the sets. Note also that each of the  $k$  sets are evaluated for  $A_T^S$  in the same interval  $T$ .

Alternate ways of calculating  $A_T$  for the group of sets is for further study.

## 10. UNI Requirements

This section specifies requirements for UNI Type in addition to providing a recommended approach to supporting resiliency and synchronization services.

The UNI requirements might not be uniform for all UNIs in the Mobile Backhaul. This document distinguishes the requirements for the UNI at the RAN BS and the UNI at the RAN NC, as illustrated in the Service Model of Figure 9, when necessary. Requirements specified for the UNI apply to both the RAN BS UNI and RAN NC UNI, unless specified otherwise.

RAN BS and RAN NC can be considered as a single device, such as a base station or network controller/gateway, or site with several network devices. As per MEF 11 [9], it is assumed that the UNI-C or UNI-N functions can be distributed across one or more devices.

### 10.1 UNI Type

[R11] The UNI at a RAN CE site **MUST** be compliant with a UNI Type 1.2 as per MEF 13 [11] to support E-Line and E-LAN services defined in MEF 6.1 [3].

Compliance to UNI Type 1.2 is validated with ATS for UNI Type 1 (MEF 19 [15]). It is possible for a UNI Type 1.2 to be enhanced with certain capabilities defined for UNI Type 2 (MEF 20 [16]), and not require full compliance to UNI Type 2.1 or UNI Type 2.2. These enhancements are necessary for a UNI Type 1.2 to support all MEF Services defined in MEF 6.1 [3]. Such partial compliance of relevant sections of UNI Type 2 can be validated with MEF 21 [17], MEF 24 [19], MEF 25 [20] and MEF 27 [21].

[R12] A UNI that is compliant to UNI Type 1.2 **MUST** also be compliant with UNI PHYs listed in [R78] of MEF 20 [16] to support Services defined in MEF 6.1 [3].

[D4] If E-Tree services as defined in MEF 6.1 [3] are to be supported then the UNI that is compliant to UNI Type 1.2 **SHOULD** also be compliant with [R75, R76 and R77] in Section 12 (Enhanced UNI Attributes) of MEF 20 [16].

[R13] A UNI that is compliant to UNI Type 1.2 **MUST** also be compliant with [R73 and R74] in Section 12 (Enhanced UNI Attributes – MTU size) of MEF 20 [16] to support Services defined in MEF 6.1 [3].

[R14] A UNI that is compliant to UNI Type 1.2 **MUST** also be compliant with [R79 and R80] in Section 12 (Enhanced UNI Attributes – Auto negotiation) of MEF 20 [16] to support Services defined in MEF 6.1 [3].

[R15] A UNI **MUST** have multiple Speed advertisement (10/100 and 10/100/1000) disabled by default for the PHYs that support Auto-negotiation.

Fiber PHYs do not use Auto-negotiation for setting speed but can be used for other capabilities like detecting port failures. Also, 1G/10G Base-T Copper PHYs require use of auto-negotiation for other capabilities (including Master/Slave determination that is critical for timing direction). A MEN Operator can enable Speed advertisement in Auto-negotiation for a UNI compliant to [R14]. It should be noted that both RAN CE and MEN UNIs need to be in same Auto-negotiation state, i.e., disabled or enabled.

[R16] A RAN BS UNI **MUST** support at least 2 EVCs.

[D5] A RAN BS UNI **SHOULD** support at least 4 EVCs.

- [O5] A RAN BS UNI **MAY** support minimum number of EVCs per MEF 13 [11].
- [R17] A RAN NC UNI **MUST** support minimum number of EVCs per MEF 13 [11].
- [O6] A UNI that is compliant to UNI Type 1.2 **MAY** also be compliant with [R70, R71 and R72] in Section 12 (Enhanced UNI Attributes – Egress Bandwidth Profile) of MEF 20 [16] to support E-LAN and E-Tree Services defined in MEF 6.1 [3] since it is optional in MEF 6.1 [3].
- [D6] When VLAN based services are supported at a UNI then Ingress Bandwidth Profile (I-BWP) per UNI **SHOULD NOT** be used.
- [D7] When VLAN based services are supported at a UNI then Egress Bandwidth Profile (E-BWP) per UNI **SHOULD NOT** be used.
- [D8] The UNI **SHOULD** be compliant with a UNI Type 2.1 as per MEF 20 [16].
- [O7] The UNI **MAY** be compliant with a UNI Type 2.2 as per MEF 20 [16].
- [R18] A MEF compliant UNI **MUST** support L2CP processing per MEF 6.1.1.

UNI Type 1 and Type 2 can support configuration of CIR and EIR in granularities mentioned in Section 6.2.5 of UNI Type 1 (MEF 13 [11]). The NGMN Alliance has recommended values (in Section 4.2) [88] for granularities for Peak and Average Bandwidths. Ignoring the differences in terms used, such as Peak Bandwidth, a MEF compliant UNI supports a 1Mbps granularity for CIR and EIR up to 10Mbps while [88] recommends 2Mbps granularity for up to 30Mbps. Also, for the 10-100Mbps range the MEF compliant UNI's granularity is 5Mbps while [88] recommends 10Mbps. Finally, while MEF compliant UNI will support 50Mbps steps for the range 100Mbps-1Gbps and 500Mbps steps beyond 1Gbps, [88] recommends 100Mbps steps for bandwidth >100Mbps.

Furthermore, the UNI at RAN CE will need to properly account for the differences in how Peak, Peak Access, Effective and Average Bandwidth, terms mentioned in the NGMN Alliance specification [88], are calculated as compared to the Ingress and Egress Bandwidth Profile parameters defined in MEF 10.2 [7] for the CoS Name at the UNI. It is critical, however, to clarify that MEF's Bandwidth Profile parameters at the UNI are defined based on the Service Frame at the UNI (MEF 10.2 [7]). It is not possible for this IA to provide recommendations since there are no precise definitions for the terms used in the NGMN Alliance specification [88] and a RAN CE might additionally employ header compression for the IP Packets.

## 10.2 GIWF's UNI Requirements

Use case 1a in Section 7.1.1 has a SP delivering Mobile Backhaul service at a TDM demarcation using a GIWF with TDM interface to the RAN CEs. The SP uses a MEN for some or all traffic between TDM-interface based mobile equipments in the RAN BS and RAN NC. Requirements on a GIWF's UNI are dependent on UNI Type as discussed in Section 10.1.

- [R19] The GIWF's UNI **MUST** comply with all requirements, for the UNI Type implemented, as defined in this IA.

This IA is agnostic to the mechanisms used to adapt TDM-interface based RAN BS and RAN NC to MEF defined services across a MEN. Requirements specific to CES across the MEN are

defined in MEF 3 [1], MEF 8 [5] and IP/MPLS Forum 20.0.0 [76] and are out of scope for this IA.

### 10.3 UNI Resiliency

A MEN operator can support UNI implementations to enable Services or Synchronization architecture that is resilient to some UNI failure scenarios. One example is Link Aggregation [16] for port protection or line card protection. In addition, there might be the option to have multiple UNIs to the same RAN CE site where UNIs can be on the same NE or different NEs. Typically, it is expected that the RAN NC site might have more complex implementations than RAN BS sites.

**[D9]** A UNI at a RAN NC site **SHOULD** use Link Aggregation for UNI Resiliency as defined for UNI Type 2 in MEF 20 [16].

**[O8]** A UNI at a RAN BS site **MAY** use Link Aggregation for UNI Resiliency as defined for UNI Type 2 in MEF 20 [16].

**[R20]** If a UNI that is compliant to UNI Type 1.2 uses UNI Resiliency with Link Aggregation then it **MUST** comply with the requirements in Section 11 of MEF 20 [16] but modified per this IA.

**[R21]** Link Aggregation group, across the ports supporting an instance of UNI, for UNI Resiliency **MUST** have exactly two (2) links.

Note that R63 and R64 of MEF 20 [16] allow ‘at least two (2) links’. This IA is requiring exactly two (2) links when Link Aggregation is used for UNI Resiliency. Link Aggregation with links on multiple line cards is recommended in [R65] of MEF 20 [16]. Other implementations such as Link Aggregation with >2 links are not covered in the current phase of this IA.

**[R22]** When Link Aggregation of exactly two (2) links is implemented for UNI Resiliency then the links **MUST** be on different line cards for a UNI at RAN NC site.

**[R23]** When Link Aggregation of exactly two (2) links is implemented across line cards, one of the links **MUST** be set to Selected while the other is set to Standby using LACP, as per IEEE 802.1AX-2008 [25] to simplify the bandwidth profile enforcement.

IEEE 802.1AX [25] uses the terms Selected, Unselected or Standby. A link in Selected state is used to send/receive frames. A link when Unselected is not part of Link Aggregation Group. A link in Standby is not used to send/receive frames. In the case of Link Aggregation with exactly 2 links for the UNI the Selected link is said to be active for all CoS Frame Sets at the UNI.

In addition to line card diversity there might be a need to enhance the resiliency to failure by specifying additional constraints such as UNI overlap for diverse sets of ordered UNI pairs as defined in Section 9.2.1.

### 10.4 UNI PHY for Synchronization Service

This section specifies Synchronous Ethernet capability so that the MEN operator can offer a Synchronization Service typically with a PRC traceable frequency reference towards the Mobile Operator’s RAN BS sites. The case when a Mobile Operator owns the PRC is for further study.



[O9] Synchronous Ethernet, with a UNI PHY capable of operating in Synchronous mode as specified in this IA, **MAY** be used to deliver a PRC traceable frequency reference to the RAN BS site.

It is expected that the MEN Operator will enable Synchronous Ethernet with or without ESMC (ITU-T G.8264 [34]) at specific RAN BS sites when needed. ESMC is a protocol used to indicate the quality level of the clock. There are two aspects to consider:

1. UNI PHY can operate in Synchronous mode, and,
2. UNI PHY operating in Synchronous mode with ESMC support and with or without QL indication for PRC traceability

[R24] If Synchronous Ethernet is used for frequency synchronization service at the RAN BS UNI then the requirements [R25] to [R36] **MUST** apply.

**10.4.1 UNI PHY with Synchronous mode**

MEF 10.2 [7] specifies UNI physical layer service attribute (Speed, Mode and physical medium) with Full duplex as the option for Mode. This IA extends the Mode attribute to define Full Duplex with Synchronous or Asynchronous modes. Asynchronous mode refers to interface operating with physical layer frequency as specified in IEEE 802.3-2008 [26] e.g., transmit clock frequency of 125MHz +/-0.01% for 100BASE-SX interface. In ITU-T G.8264 [34] this is referred to as Non-synchronous operation mode (on the transmit side). Synchronous operation mode (ITU-T G.8264 [34]), on the transmit side, refers to the case when the frequency is driven from the EEC. Such an operation mode, however, might not have the EEC locked to any external clock source.

[R25] If UNI PHY can support Synchronous mode of operation then UNI Physical layer Attribute Mode (MEF 10.2 [7]) **MUST** be used to choose Asynchronous or Synchronous mode of operation for UNI.

[R26] If UNI PHY can support Synchronous mode of operation then the default state **MUST** be disabled as shown in Table 2, e.g., in Full Duplex Asynchronous mode.

Administrative Action	Mode
Disabled (Default)	Full Duplex Asynchronous mode with ESMC and QL process disabled
Enabled	Full Duplex Synchronous mode

Table 2: UNI Physical layer attribute – Mode

[R27] If UNI PHY can support Synchronous mode of operation then it **MUST** support the option to administratively, i.e., using a NE’s management interface, enable or disable Synchronous mode of operation.

**10.4.2 ESMC Protocol (L2CP) on UNI PHY**

The protocol uses the slow protocol address as specified in Annex 57B of IEEE 802.3-2008 [26] and no more than 10 frames per second can be generated for all protocols using slow protocol address. ESMC frames are sent at 1 frame per second.

[R28] The ESMC protocol at UNI PHY **MUST** be configurable by administrative methods, i.e., using a NE’s management interface

[R29] The ESMC Frame format **MUST** be as specified in ITU-T G.8264 [34].

[R30] If UNI PHY is in Synchronous mode then ESMC protocol processing **MUST** be enabled by default as shown in Table 3.

Administrative Action	ESMC processing
Disabled	Transmit: No generation of ESMC Frames Receive: discard ESMC Frames if any received due to misconfiguration errors, for example.
Enabled (Default)	Transmit: Generate ESMC Frames Receive: Peer ESMC Frames

Table 3: ESMC Protocol

The terms transmit and receive are used in this IA since the requirements apply to MEN and RAN CE. MEF 10.2 [7] uses ingress and egress but this is always with respect to MEN, i.e., ingress is towards MEN and egress is towards CE.

[R31] A MEN’s UNI PHY in Synchronous operation mode, with ESMC protocol enabled as shown in Table 3, **MUST NOT** be a selectable clock source for the MEN.

While a RAN CE UNI in synchronous mode will be compliant to [R35] the requirement [R31] is to ensure that under any condition the direction of clock distribution is from MEN to a RAN BS. When ESMC is disabled the actual frequency of the UNI PHY can still be driven from the EEC if in Synchronous mode. See Section 10.2 in ITU-T G.8264 [34] for non-synchronous operation mode.

This IA has specified the option of using Link Aggregation for UNI resiliency in Section 10.3 with exactly 2 links. Both Link Aggregation and ESMC use slow protocols. However, Link Aggregation operates above any other IEEE 802.3 sublayer, (IEEE 802.1AX-2008 [25]) including the ESMC. In fact the OAM sublayer presents a standard IEEE802.3 MAC service interface to the superior sublayer. Superior sub-layers include MAC client and Link Aggregation. Furthermore, a Synchronous Ethernet link and associated ESMC and QL remain independent of Link Aggregation state being in Selected/UnSelected/Standby.

When both physical links in the Link Aggregation are configured to be in Synchronous Ethernet operation mode, with ESMC enabled carrying its own ESMC channel and related QL, then the configuration needs to be consistent for both links. Further considerations on the implications of

having multiple SyncE links, with or without Link Aggregation, connecting two nodes are planned to be included in future releases of ITU-T G.8264 [34].

**10.4.3 QL process support on UNI PHY in Synchronous mode**

QL is used to design the synchronization network in order to properly handle fault conditions. In particular, QL can help in prevention of timing loops. In a typical deployment it is expected that the timing distribution is unidirectional (i.e., MEN to RAN BS).

[R32] The QL process, with ESMC enabled, **MUST** support states as shown in Table 4.

Administrative action	QL Indication
QL Disabled ITU-T G.781 [39]	Transmit: Set QL TLV=DNU or DUS Receive: Ignore QL TLV
QL Enabled (Default)	Transmit: Set QL TLV Receive: Process QL TLV

Table 4: QL process support in Synchronous operation mode

[R33] UNI PHY in Synchronous operation mode, with ESMC protocol enabled as shown in Table 3, **MUST** have QL process enabled by default as shown in Table 4.

[R34] The QL mode of operation at UNI **MUST** be configurable by administrative methods, i.e., using a NE’s management interface.

[R35] RAN CE UNI PHY in Synchronous operation mode, with ESMC protocol enabled as shown in Table 3, **MUST** set QL TLV=DNU or DUS per ITU-T G.781 [39] in ESMC frames transmitted towards MEN.

[R36] If QL process is disabled, with ESMC protocol enabled, at a MEN’s UNI PHY for any operational reason then ESMC frames **MUST** be sent by MEN’s UNI with QL-TLV=DNU or DUS (ITU-T G.8264 [34]).

In some deployments there might be UNI designs with >1 UNI to the same RAN BS site. With >1 UNI a MEN operator could provide clock distribution from multiple PRC sources so the RAN BS can use QL to select the highest traceable clock. This would be useful if for some reason a traceable reference is lost on one UNI.

Furthermore, even with 1 UNI to a RAN BS site, QL value with a DNU message can allow a RAN CE’s UNI to go in to hold-over mode until such time the fault condition (absence of traceable reference) is corrected. More importantly, RAN CE’s UNI will use its internal clock source and not synchronize to the holdover clock of the MEN nodes that could potentially be lower quality than its internal clock source.

However, ITU-T G.8264 [34] allows certain applications, such as in access networks, where a RAN CE’s UNI might be able to recover frequency from the Synchronous Ethernet interface without needing to process ESMC or QL.



A MEN's UNI will need to be capable of generating Ethernet Synchronization Messaging Channel (ESMC) messages assuming RAN CE's UNI requires a traceable frequency reference and clock quality indication. Also, all values of QL as specified in ITU-T G.781 [39] will need to be supported. The requirements are to ensure that MEN NEs supporting UNI-N at RAN BS are capable of Synchronous Ethernet with support for QL mode of operation if a RAN CE's UNI is capable of processing the messages. Some operators might also choose to enable this only when wanting to offer traceability to a PRC with QL mode as enhanced capability to a basic Synchronous Ethernet frequency reference service.

Additional Interface Limits at the UNI for Jitter and Wander are included in Section 12.3 when Synchronous Ethernet is used for Synchronous Service.

## **10.5 UNI Service Attributes**

MEF 6.1[3] identifies the parameter values for Service Attributes of each service defined in that specification – E-Line, E-LAN, and E-Tree. The following table lists the UNI attributes with values from MEF 6.1[3] as well as from MEF 13[11] and additional constraints, if any, as specified in this IA.

### 10.5.1 VLAN based MEF 6.1 Services

Per UNI Service Attribute	MEF 6.1 [3] EVPL	MEF 6.1 [3] EVP-LAN	MEF 6.1 [3] EVP-Tree	MEF 13 [11] UNI Type 1.2 (UNI-N)	This IA (EVPL/EVP-LAN/EVP-Tree)
UNI Identifier	Arbitrary text string to identify the UNI				No additional constraints
PHY	UNI Type 2 Physical Interface except for PON interfaces			1000B-PX-D/U not included	Section 10.1 See [R12] if UNI Type 1.2
Speed	10 Mbps, 100 Mbps, 10/100 Mbps Auto-negotiation, 10/100/1000 Mbps Auto-negotiation, 1 Gbps, or 10 Gbps			Same	Section 10.1 See [R14] to support Auto-negotiation.  See [R15] for PHYs that support Auto-negotiation
Mode	<b>MUST</b> be Full Duplex			Same	Section 10.4 UNI PHY in Synchronous mode
MAC Layer	IEEE 802.3-2005			Same	No additional constraints
UNI MTU Size	<b>MUST</b> be $\geq 1522$			Frame Formats per IEEE 802.3-2002 (min/max)  <b>MUST</b> support CBS $\geq 8 \times \text{MTU}$ with MTU=1522	See Section 11.6 for EVC attributes. Also, EVC MTU $\leq$ UNI MTU per MEF 10.2 [7]  Section 10.1: See [R13] for MTU sizes, i.e., <b>MUST</b> :1522, <b>SHOULD</b> : 2000, <b>MAY</b> : 9600
Service Multiplexing	<b>SHOULD</b> be supported at one or more UNIs.			<b>MUST</b> Support	No additional constraints
Bundling	Yes or No. If Yes, then CE-VLAN ID Preservation <b>MUST</b> be Yes.			<b>MUST</b> Support  <b>MUST</b> have configurable CE-VLAN/EVC mapping table	No additional constraints
All to One Bundling	<b>MUST</b> be No				No additional constraints
CE-VLAN ID for untagged / priority tagged	<b>MUST</b> specify CE-VLAN ID for untagged and priority tagged Service Frames in the range of 1-4094.			Frame Formats (IEEE 802.3-2002) <b>MUST</b> have a configurable CE-VLAN ID/EVC mapping table	No additional constraints

Per UNI Service Attribute	MEF 6.1 [3] EVPL	MEF 6.1 [3] EVP-LAN	MEF 6.1 [3] EVP-Tree	MEF 13 [11] UNI Type 1.2 (UNI-N)	This IA (EVPL/EVP-LAN/EVP-Tree)
# of EVCs	<b>Maximum MUST</b> be $\geq 1$			<b>SHOULD</b> support minimum EVCs: 10/100Mb/s: 8 1Gb/s: 64 10Gb/s: 512  <b>SHOULD</b> support minimum CE-VLAN IDs: 10/100Mb/s: 8 1Gb/s: 64 10Gb/s: 512	Section 10.1: See [R11] for MEF UNI Type 1.2 but with Minimum# of EVCs specified by - RAN BS UNI: See [R16], [D5] and [O5] - RAN NC UNI: See [R17]  Minimum CE-VLAN IDs: No additional constraints.
Traffic Management I-BWP per UNI	<b>OPTIONAL</b> . If supported, <b>MUST</b> specify <CIR, CBS, EIR, EBS, CM, CF>. <b>MUST NOT</b> be combined with any other type of ingress bandwidth profile.			<b>MUST</b> Support 1) I-BWP per UNI 2) Color blind 3) CIR/EIR Granularity 4) CBS $\geq (8 * MTU)$	Section 10.1 See [D6] for not using I-BWP per UNI.  Section 10.1 Discussion on NGMN [88] requirements for granularity
Traffic Management E-BWP per UNI	<b>OPTIONAL</b> . If supported, <b>MUST</b> specify <CIR, CBS, EIR, EBS, CM, CF>. <b>MUST NOT</b> be combined with any other type of egress bandwidth profile.				Section 10.1 See [D7] for not using E-BWP.  See [O6] for Enhanced UNI attributes (E-BWP per EVC and per CoS ID).
L2CP Processing	<b>MUST</b> specify in accordance with Section 8 of [MEF 6.1]			<b>MUST/SHOULD</b> rules based on Protocol	Section 10.1 See [R18] for L2CP Processing  Section 10.4 ESMC processing

Table 5: Per UNI Service Attributes for VLAN based MEF 6.1 [3] Services

### 10.5.2 Port based MEF 6.1 Services

Cells in Table 6 have been highlighted if MEF 6.1 [3] service attributes have different requirements than for VLAN based Services.

Per UNI Service Attributes	MEF 6.1 [3] EPL	MEF 6.1 [3] EP-LAN	MEF 6.1 [3] EP-Tree	MEF 13 [11] UNI Type 1.2 (UNI-N)	This IA (EPL/EP-LAN/EP-Tree)
UNI Identifier	Arbitrary text string to identify the UNI				No additional constraints

Per UNI Service Attributes	MEF 6.1 [3] EPL	MEF 6.1 [3] EP-LAN	MEF 6.1 [3] EP-Tree	MEF 13 [11] UNI Type 1.2 (UNI-N)	This IA (EPL/EP-LAN/EP-Tree)
PHY	UNI Type 2 Physical Interface except for PON interfaces			1000B-PX-D/U not included	Section 10.1 See [R12] if UNI Type 1.2
Speed	10 Mbps, 100 Mbps, 10/100 Mbps Auto-negotiation, 10/100/1000 Mbps Auto-negotiation, 1 Gbps, or 10 Gbps			Same	Section 10.1 See [R14] to support Auto-negotiation.  See [R15] for PHYs that support Auto-negotiation
Mode	<b>MUST</b> be Full Duplex			Same	Section 10.4 UNI PHY in Synchronous mode
MAC Layer	IEEE 802.3-2005			Same	No additional constraints
UNI MTU Size	<b>MUST</b> be $\geq 1522$			Frame Formats per IEEE 802.3-2002 (min/max) <b>MUST</b> support CBS $\geq 8 \times \text{MTU}$ with MTU=1522	See Section 11.6 for EVC attributes. Also, EVC MTU $\leq$ UNI MTU per MEF 10.2 [7]  Section 10.1: See [R13] for MTU sizes, i.e., <b>MUST</b> :1522, <b>SHOULD</b> : 2000, <b>MAY</b> : 9600
Service Multiplexing	<b>MUST</b> be No				No additional constraints
Bundling	<b>MUST</b> be No.				No additional constraints
All to One Bundling	<b>MUST</b> be Yes			<b>MUST</b> Support	No additional constraints
CE-VLAN ID for untagged / priority tagged	All untagged and priority tagged Service Frames at the UNI <b>MUST</b> map to the same EVC as is used for all other Service Frames.			Frame Formats (IEEE 802.3-2002) <b>MUST</b> have a configurable CE-VLAN ID/EVC mapping table	No additional constraints
# of EVCs	Maximum <b>MUST</b> be = 1				No additional constraints. See [R42] in Section 11.5.1: at least 2 CoS Frame Sets,
Traffic Management I-BWP per UNI	<b>MUST NOT</b> specify	<b>OPTIONAL</b> . If supported, <b>MUST</b> specify <CIR, CBS, EIR, EBS, CM, CF>. <b>MUST NOT</b> be combined with any other type of ingress bandwidth profile.		<b>MUST</b> Support 1) I-BWP per UNI 2) Color blind 3) CIR/EIR Granularity 4) CBS $\geq 8 \times \text{MTU}$	Section 10.1 Discussion on NGMN [88] requirements

Per UNI Service Attributes	MEF 6.1 [3] EPL	MEF 6.1 [3] EP-L AN	MEF 6.1 [3] EP-Tree	MEF 13 [11] UNI Type 1.2 (UNI-N)	This IA (EPL/EP-LAN/EP-Tree)
Traffic Management E-BWP per UNI	<b>MUST NOT</b> specify	<b>OPTIONAL.</b> If supported, <b>MUST</b> specify <CIR, CBS, EIR, EBS, CM, CF>. <b>MUST NOT</b> be combined with any other type of egress bandwidth profile.			Section 10.1 See [O6] for Enhanced UNI attributes (E-BWP per UNI, per EVC and per CoS ID).
L2CP Processing	<b>MUST</b> specify in accordance with Section 8 of [MEF 6.1]			<b>MUST/SHOULD</b> rules based on Protocol	Section 10.1 See [R18] for L2CP Processing  Section 10.4 ESMC processing

Table 6: Per UNI Service Attributes for Port based MEF 6.1 [3] Services

## 11. EVC Requirements

This section specifies requirements for service attributes and performance metrics for CoS Frame Sets in addition to providing a recommended approach to supporting various traffic classes in the Mobile Backhaul service. The Mobile Operator might require different performance metrics for each of the CoS Frame Sets. Each CoS Frame Set across a certain performance tier (MEF 23.1 [18]), identified by a CoS ID, can have an SLS specified for the set *S* of ordered UNI pairs with UNIs in the EVC. The EVC performance is one of the EVC attributes defined per CoS ID (MEF 6.1 [3], MEF 10.2 [7], and MEF 10.2.1 [8]).

In Section 7.2, [R1] requires compliance to the EVC attributes for the services defined in MEF 6.1 [3]. The EVC related attributes as specified in MEF 6.1 for VLAN and Port based services are listed in Section 11.6.

### 11.1 Maximum Number of UNIs

The Mobile Operator might have few hundred to thousand or more RAN BS sites in a given metro or region. Some traffic classes, such as management, control, packet method for synchronization, video multicast or broadcast, etc., might require a multipoint service and the service might be to some or all UNIs within that metro or region. For example, assuming that each RAN BS UNI in the EVC is configured for a CIR of 100Mb/s, one 10 Gigabit Ethernet port at RAN NC can support 100 UNIs (assuming no over subscription).

**[D10]** A multipoint Mobile Backhaul service **SHOULD** be capable of supporting Maximum number of UNIs in the EVC to be  $\geq 100$ .

A Mobile Operator can use less or more number of UNIs in the EVC. However, a MEN Operator is required to have this minimum capability.

## 11.2 EVC MTU

MEF 6.1 [3] requires a minimum of 1522 bytes for the EVC MTU. In the case of a Mobile Backhaul service for LTE a RAN BS can include additional encapsulation headers for user and control traffic classes as indicated in the protocol stacks discussed in 3GPP TS 36.300 [74]. In addition there might be variations depending on IP version as well as use of IPSec or header compression. In some deployments support for larger frames size might be necessary. For example, in LTE, with a user traffic payload size of 1500 bytes and headers for GTP (20 bytes), IPv6 (40 bytes) and IEEE 802.1Q Ethernet (22 bytes), the frame size can be 1582 bytes. However, recognizing the issues that may be introduced with larger MTU sizes in backhaul for LTE, Annex C of 3GPP TS 23.060 [59] has suggested options to limit the user traffic payload size to a maximum of 1358 bytes for most network deployments.

This IA is not specifying a higher minimum value for the EVC MTU given the various options for headers. However, this IA is alerting the Mobile and MEN Operators to consider the encapsulation overhead when deciding a suitable EVC MTU.

## 11.3 Set of ordered UNI pairs

This section specifies requirements for the set  $S$  that has SLS defined with the metrics from MEF 10.2 [7], MEF 10.2.1 [8] and this IA.

**[R37]** The triple  $\{S, \text{CoS ID}, \text{PT}\}$  (MEF 23.1 [18]) **MUST** be specified for each CoS Frame Set in the Mobile Backhaul Service.

**[D11]** If E-Line is used for Mobile Backhaul service then set  $S$  **SHOULD** include both ordered UNI pairs.

In some use cases the performance metrics might be different for the two ordered pairs. In such cases it is preferable to have separate set for each ordered pair. Hence, this IA is not requiring that both ordered pairs for an E-Line service be in the same set.

**[O10]** If E-LAN or E-Tree is used for Mobile Backhaul service then a set  $S$  **MAY** have subset of ordered UNI pairs.

For example, as discussed in Section 7.2, a E-LAN service could support connectivity between RAN BSs only or include RAN NC sites. In this case there can be different performance considerations for the subset that includes only UNIs at RAN BS sites, e.g. for X2 in LTE, in contrast to the subset that includes RAN NC site, e.g. for S1 in LTE. These are different CoS Frame Sets. In addition these subsets can also be across different performance tiers (PT), i.e., X2 across a PT1 (metro) while S1 is across a PT2 (regional) as described in MEF 23.1 [18].

**[O11]** If E-LAN or E-Tree is used for Mobile Backhaul service then set  $S$  **MAY** contain all ordered UNI pairs.

## 11.4 EVC Performance

MEF 6.1 [3] has EVC Performance per CoS ID with  $\{\text{FLR}, \text{FD}, \text{FDV}, \text{A}\}$ . This does not include all metrics specified in MEF 10.2 [7], MEF 10.2.1 [8] and this IA. Also, per MEF 23.1 [18], SLS has to be specified for a CoS Frame Set identified by the triple  $\{S, \text{CoS ID}, \text{PT}\}$ . While an SLS



includes the metrics and parameters for each CoS Frame Set it is possible to have some or all of these metrics as Not Specified (N/S) in the SLS.

**[R38]** The EVC Performance for the CoS Frame Set **MUST** include {FLR, FD, FDR, MFD, IFDV, A, HLI, CHLI} metrics and parameters as defined in MEF 10.2 [7], and MEF 10.2.1 [8].

While the EVC Performance service attribute in MEF 6.1 [3] refers to ‘Frame Delay Variation’ MEF 10.2 [7] has updated the name to be Inter-Frame Delay Variation (IFDV). Also, MEF 10.2.1 [8] has updated the definition for Availability metric in addition to including Resiliency metrics. The Mobile Operator (Subscriber) uses the Availability objective to understand the long term (e.g.  $T=1$  month) performance but uses counts  $\hat{L}$  (for HLI) and  $\hat{B}$  (for CHLI) metrics to understand the type of short term disruptions during the interval  $T$ .

Specifying an objective for the Availability attribute is customer and CoS Name specific and might be negotiated as part of the SLS. Also, future phases of MEF 23.1 [18] might specify CPOs for MEF CoS Labels that can be used by the Operators if MEF Standard CoS Labels are to be used. The NGMN Alliance specification [88] recommends Availability objective of 99.99% for the Backhaul excluding eNB and aGW failures.

The total number of HLIs and CHLIs allowed during a measurement period might also be negotiated as part of the SLS. For example, a Mobile Operator can choose an objective of no more than 10 events of 2 or more CHLI and no more than 25 HLI events during a measurement time period of 1 month. So a MEN that reports, for example, 6 events of 3 CHLI, and 1 event of 5 CHLI is in compliance with the SLS since the total 23 HLI reported for the measurement time has also not exceeded the objective for HLI. Future phases of MEF 23.1 [18] might include these metrics and define the CPO for the MEF CoS Labels.

MEF 23.1 [18] requires either IFDV or FDR but not both. Also, MEF 23.1[18] requires either MFD or FD but not both. The Mobile Operator has the option to select the metrics depending on the traffic class, e.g., Conversations such as voice vs streaming such as video. Thus, the EVC Performance attribute per CoS ID for some traffic class might be: {FLR, FD=N/S, FDR, MFD, IFDV=N/S, A, HLI, CHLI}, where FD, IFDV are not specified since MFD and FDR are specified in this example.

#### 11.4.1 Performance for Synchronization Traffic Class

Packet method can be used for frequency synchronization as discussed in Section 12.2. The CoS Frame Set, in the Mobile Backhaul service supporting synchronization traffic class, might need to meet a delay objective, when compared to the minimum delay, during the time interval of interest. Section 11.5.1 has additional discussion clarifying that not all use cases of packet based synchronization traffic class require the same performance requirements.

The Frame Delay Range (FDR) metric is defined in MEF 10.2 [7] and simplified in MEF 23.1 [18] with one Percentile,  $P_r$ . This FDR metric is similar to Packet Delay Variation (PDV) defined in ITU-T Y.1541 [29] for IP Packets and Frame Delay Variation (FDV) defined in ITU-T Y.1563 [30] for Ethernet Frames. The relevant parameters in the FDR metric are the time interval  $T$  (e.g. 1 month), the Subset  $S$  of ordered UNI pairs of the EVC and Percentile  $P_r$  of the Frame population that meets the Frame Delay Range metric,  $\bar{d}_{TrS}$ . The FDR is the maximum

across all the ordered UNI pairs in Set  $S$ . The minimum delay, determined during the time interval  $T$ , is used to determine the delay difference of Frames in the CoS Frame Set. During each measurement interval (e.g., 900 seconds), a certain minimum number of Frames in this CoS Frame Set will need to meet the FDR metric.

**[R39]** If a CoS Frame Set is used for synchronization traffic class (i.e., packet method as described in Section 12.2) then the EVC Performance **MUST** have FDR specified, i.e., not N/S, in the SLS for the CoS ID.

The parameter values and objective for FDR might be included in a future phase of this IA.

#### 11.4.2 Performance with MEN Resiliency

The MEN Operator can offer a Mobile Backhaul service that is resilient to failure by choosing to associate an EVC to 1 or more diverse connections in the MEN. There might be mechanisms to select a connection to improve the resiliency performance. The MEN Operator offers an SLS for the CoS Frame Set as discussed in Section 11.3 and 11.4. The mechanisms used by the MEN Operator to improve the resiliency are out of scope for this IA.

#### 11.4.3 Performance with RAN Resiliency

Mobile Operator can choose a Mobile Backhaul service with 2 or more diverse sets of ordered UNI pairs across the MEN Operator that might be individually resilient to failure. The diverse sets might be from a single EVC (e.g., E-LAN or E-Tree) or might be from 2 or more EVCs. The diverse sets are as discussed in Section 9.2.1 with the Mobile Operator identifying the sets that do not share the same risk of faults across the MEN including, optionally, at the UNI. The MEN Operator offers the SLS for each set and includes performance attributes such as Availability, HLI and CHLI as discussed in Section 11.4. In addition, the SLS can include the resiliency performance for the group of diverse sets.

Figure 18 shows one example where different UNIs serve different BS sites with EVC per BS site and having full diversity. The ESRG attribute is now used by the MEN Operator to assign resources with diverse facility SRG in the MEN. In this case, the Mobile Operator is using RAN Resiliency to improve its Radio Resiliency performance.

The Mobile Operator can also choose to have both UNIs serve the same RAN BS site but instead only require the sets to that BS site be fully or partially diverse. Of course, the Mobile Operator could purchase EVCs from different MEN Operators as well.

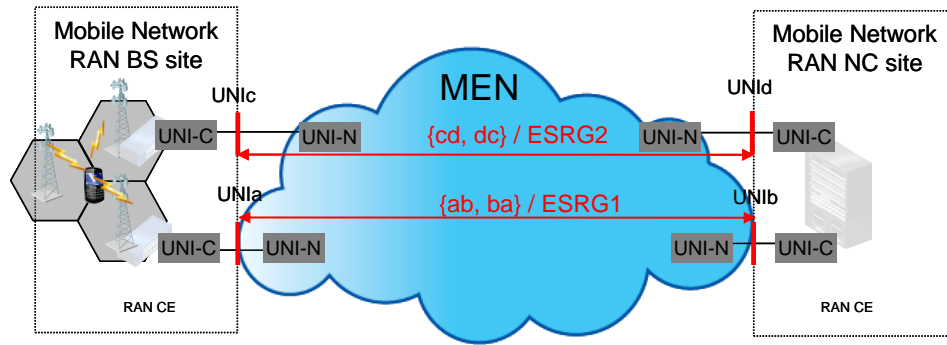

Figure 18: RAN based Resiliency using diverse EVCs and optionally diverse UNIs.

- [D12] A MEN Operator **SHOULD** support the capability to offer fully diverse sets of ordered UNI pairs with conformance to [R9] .
- [D13] A MEN Operator **SHOULD** support the capability to offer partially diverse sets of ordered UNI pairs with conformance to [O4].

If partial diversity is sufficient then the Mobile Operator can negotiate with the MEN Operator, as part of the SLS, on the facility SRGs where the sets might not be diverse. For example, the sets might have common UNI at a RAN BS site but can be diverse at RAN NC sites as shown in Figure 19.

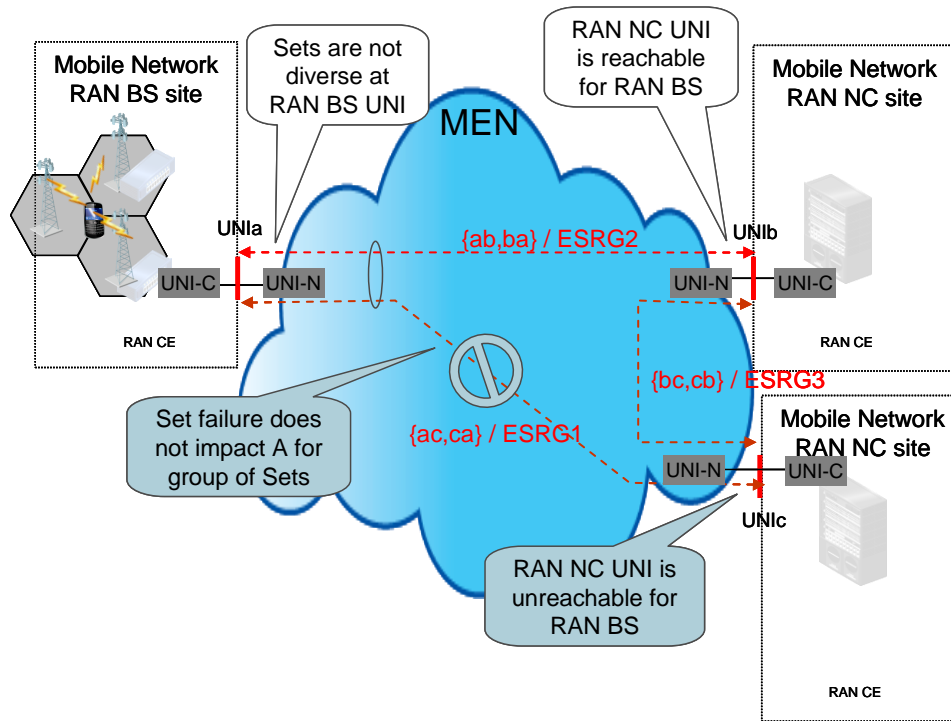

Figure 19: Partial diversity with common UNI at RAN BS site

- [R40] If the SLS for the Mobile Backhaul service includes objective (i.e., it is not N/S) for Availability  $A_T$  metric in the interval  $T$ , for a group of diverse sets, then each of the sets in the group  $\{S_k \mid k=1, 2, \dots\}$  **MUST** be defined as specified in Section 9.2.1 with the sets in the group compliant to either full or partial diversity.
- [R41] If the SLS for the Mobile Backhaul service includes objective (i.e., it is not N/S) for Availability  $A_T$  metric in the interval  $T$ , for a group of diverse sets, then the metric  $A_T^S$  **MUST** also be specified with an objective (i.e., it is not N/S) for each of the sets in the group  $\{S_k \mid k=1, 2, \dots\}$ .
- [D14] If the SLS for the Mobile Backhaul service includes objective (i.e., it is not N/S) for Availability  $A_T$  metric in the interval  $T$ , for a group of diverse sets, then  $A_T$  **SHOULD** be determined as specified in Section 9.2.2.

Additionally, UNI Resiliency requirements such as in Section 10.3 can also apply.

## 11.5 Class of Service for Mobile Backhaul

Mobile standards defined by 3GPP, 3GPP2, and IEEE 802.16 do not define requirements for the number of service classes that must be available in an Ethernet or IP based Mobile Backhaul network, but do identify user traffic classes on the radio interface. Section Appendix B (Appendix B) is an informative appendix that examines user traffic classes defined by some mobile standards. Traffic classes defined for various mobile standards include these user traffic

classes and additional traffic classes for management, synchronization, control, and signaling traffic types between RAN BSs and RAN NCs.

**11.5.1 CoS Names**

Mobile standards such as in 3GPP for LTE define traffic classes with a composite QCI for forwarding treatment and service performance – See Table 16 in Section Appendix B of this IA- that apply from the User’s equipment to a PCEF at a RAN NC or gateway site (3GPP 23.203 [61]). The Mobile Operator might need a certain number of CoS Names, identified by a CoS ID (MEF 10.2 [7]) across a MEN to support the traffic classes between the RAN CE. A MEN might be capable of supporting a certain number of CoS Names. If this is less than the number of traffic classes required by the Mobile Backhaul application it is possible for the Mobile Operator to aggregate traffic classes requiring similar service performance in to lesser number of CoS Names. The CoS ID for the CoS Name can be defined with more than 1 PCP or DSCP (MEF 10.2 [7]) which allows multiple traffic classes to get the same forwarding treatment in the MEN. The NGMN Alliance specification [88] includes recommendations to support at least 4 CoS Names per S1 interface per eNB (RAN BS site).

Table 7 provides an example mapping for Mobile Backhaul traffic classes into 3 and 2 MEF standard CoS Names consistent with MEF 23.1 [18], i.e., CoS Labels H/M/L, or 4 CoS Names with an additional H<sup>+</sup> CoS Name as defined in this IA. CoS Labels (i.e., H, M, L) are the names for the CoS for which CoS ID and Color ID types and values, Bandwidth Profile constraints, CPO values and parameter values are specified (MEF 23.1 [18]). The H<sup>+</sup> CoS Name, defined in this IA, might have more stringent performance objectives and parameters for FDR, IFDV, and A (MEF 10.2 [7], MEF 10.2.1 [8]) compared to H CoS Label. The forwarding treatment for H<sup>+</sup> is of higher priority than H.

CoS Names	Generic Traffic Classes <sup>2</sup> mapping to CoS Names			
	4 CoS Names	3 CoS Names	2 CoS Names	2 CoS Names
<b>Very High (H<sup>+</sup>)</b> Defined in this IA	Synchronization	-	-	-
<b>High (H)</b> Defined in [18]	Conversational, Signaling, Network Management and Control	Synchronization, Conversational, Signaling, Network Management and Control	Synchronization, Conversational, Signaling, Network Management Control, and Streaming media	Synchronization, Conversational, Signaling, Network Management, Control, and Streaming media
<b>Medium (M)</b> Defined in [18]	Streaming media	Streaming media	-	Interactive and Background
<b>Low (L)</b> Defined in [18]	Interactive and Background	Interactive and Background	Interactive and Background	

Table 7: Examples of MBH Traffic Classes mapping to CoS Names in MEN

<sup>22</sup> Mobile Backhaul User Traffic Classes (Informative)

The names of the traffic classes used in Table 7 are meant to represent a non-exhaustive set of generic traffic classes that could apply across the mobile standards referenced in this IA. Only those Mobile Backhaul traffic classes that are applicable to the transport portion of a Mobile Backhaul solution are reflected in Table 7.

**[D15]** The mapping for supporting the entire set of traffic classes (user traffic, packet-based timing, control and signaling) used generally for Mobile Backhaul **SHOULD** be based on the mapping of Generic Traffic Classes to CoS Names defined in Table 7.

A Mobile Operator can have all traffic classes including management and signaling in different CoS Names of an EVC. For example, in an LTE use case with 4 CoS Names, identified as H<sup>+</sup>/H/M/L, at the EIs of the MEN, the control and signaling traffic for S1 can use the H CoS Label while the user traffic in S1 can use the H, M and L CoS Label. The Synchronization traffic class, from a packet based method, is using H<sup>+</sup> CoS Name in this example. Further, if a separate CoS Name is needed for RAN BS management and if a MEN Operator is able to support more CoS Names in the MEN then the CoS IDs could be mutually agreed to.

A Mobile Operator could also use multiple EVCs, with each EVC providing the CoS ID for a separate CoS Name for different traffic classes including RAN BS management. The RAN BS needs the ability to classify the different traffic classes to different sets of CE-VLANs with EVC based CoS ID. MEN can then map the traffic to different EVCs at the UNI with the CE-VLAN to EVC map. Different EVCs might also be appropriate if each traffic class requires different ingress bandwidth profile but are mapped to same CoS Name, e.g. M identified by PCP 3, since CoS IDs (e.g. EVC + PCP) need to be unique.

**[R42]** A Mobile Backhaul service **MUST** support at least 2 CoS Names at UNI.

MEF 23.1 [18] allows for additional CoS Names but does not address their CoS ID or CPOs. At a MEF compliant UNI the CoS ID mechanism (e.g., EVC or EVC+PCP or EVC+DSCP) used to indicate the priority for H<sup>+</sup> CoS Name can be mutually agreed to by the Mobile Operator and MEN Operator when both MEF standard CoS Labels and other CoS Names are used at the UNI. The mapping of QCI to PCP/DSCP at the UNI-C on a RAN BS is not constrained by this IA.

**[D16]** The CoS ID mechanism for a Mobile Backhaul service **SHOULD** be based on EVC or EVC+PCP.

**[O12]** The CoS ID mechanism for a Mobile Backhaul service **MAY** be based on EVC+DSCP.

**[D17]** For a VLAN based Mobile Backhaul Service the MEN **SHOULD** set CE-VLAN CoS Preservation service attribute to Yes to support NGMN Alliance Requirement R6 in [88].

**[R43]** For a Port based Mobile Backhaul Service the MEN **MUST** set CE-VLAN CoS Preservation service attribute to Yes per MEF 6.1[3].

It is important to note that at a MEF compliant UNI, when DSCP is used for the CoS ID (MEF 10.2 [7]) to identify the CoS Name to which untagged or tagged Service Frames are mapped to, the DSCP value is preserved by default.

**[R44]** When CoS ID includes PCP or DSCP priority markings at the UNI for a CoS Label, the CoS ID mechanism and values, **MUST** be as specified in Table 3 and Table 4 of MEF 23.1 [18]



As stated in MEF 23.1 [18] a CoS ID of EVC (i.e., all possible PCP values) is allowed to be mapped to one CoS Label at the UNI in addition to other possible options such as EVC+PCP and EVC+DSCP.

This IA does not preclude using color aware Ingress bandwidth profile for the CoS Name at the UNI. When a MEN Operator supports color aware bandwidth profile then a Mobile Operator can set frames in a CoS Frame Set to be either discard ineligible (green) or discard ineligible (yellow).

**[R45]** If color aware Ingress bandwidth profile is used for a CoS Label at the UNI then Color ID **MUST** be as specified in MEF 23.1 [18].

When CoS ID is based on EVC then Color ID can be with the PCP values as specified in Table 3 of MEF 23.1 [18]. When CoS ID is based on EVC+PCP or EVC+DSCP then Color ID is as specified in Table 4 of MEF 23.1 [18]. Color ID for CoS Names not specified in MEF 23.1 [18] can be mutually agreed by Mobile and MEN Operators.

**[D18]** A MEN **SHOULD** support H and L as specified in MEF 23.1 [18] when at least two CoS Labels, are needed per UNI as shown in Table 7 of this IA.

**[O13]** A MEN **MAY** support H and M as specified in MEF 23.1 when at least two CoS Labels, are needed per UNI as shown in Table 7 of this IA.

A Mobile Operator can benefit by having a Mobile Backhaul service with more than 1 CoS Frame set. In particular, it is recommended that traffic classes such as background or interactive use CoS Label L especially when there is no need for the performance objectives of a CoS Label H or M. It is preferable if the traffic classes are mapped to at least 3 CoS Frame Sets with different performance metrics so as to efficiently use the Mobile Backhaul service. Furthermore, it is important to recognize that the H or H<sup>+</sup> CoS Name will typically be used for traffic classes with small bursts in contrast to a M or L CoS Name. A Mobile Operator needs to take this in to consideration when choosing the CoS Name for a given traffic class, i.e., conversational class vs interactive or background.

**[D19]** A MEN **SHOULD** support H, M and L as specified in MEF 23.1 [18] when at least three CoS Labels, are needed per UNI as shown in Table 7 of this IA.

One issue that could influence the suitable number of Mobile Backhaul CoS Names is the presence of some traffic classes, such as packet-based synchronization traffic. For example, if the RAN BS oscillator is stable and of high-quality then performance requirements for the CoS Name can be less stringent compared to when using a lower quality oscillator. A set of CoS Names, such as one limited to the CoS Labels (H,M,L) and associated CPOs, is most clearly applicable if synchronization is achieved either using a non-packet based method (such as GPS, SyncE, or TDM); or using a packet based method augmented by a stable high quality oscillator at the RAN BS.

It is a prerequisite that the performance requirements for a CoS Name depends on the most stringent traffic class. For example, if synchronization traffic class and voice traffic class share the same CoS Name then the performance requirements for the CoS Name are such that both traffic classes can be delivered while achieving the more stringent performance metrics of the two traffic classes.

If more stringent performance is required, this can be addressed in at least two ways: either having a single CoS Name for both synchronization traffic class and voice traffic classes or having a separate CoS Name with performance metrics suitable for the synchronization traffic class. In the former with single CoS Name the most stringent performance requirements would be derived from the synchronization traffic class and apply to voice traffic class as well. In the latter, with separate CoS Name for synchronization traffic, voice services are not affected by these stringent requirements but an additional CoS Name is required.

[D20] A MEN **SHOULD** have a dedicated CoS Name, H<sup>+</sup>, with higher forwarding priority and with performance as specified in Table 8 of this IA, for packet-based synchronization traffic class when requiring more stringent performance than the applicable SLS objectives based on CoS Label H specified in MEF 23.1 [18].

[D21] If more stringent objectives, than the applicable SLS objectives based on CoS Label H specified in MEF 23.1 [18], are needed for delay and loss sensitive packet-based synchronization then a MEN **SHOULD** support four CoS Names per UNI, including H<sup>+</sup> as shown in Table 7 of this IA.

### 11.5.2 CoS Performance Objectives (CPO)

MEF services are defined with an SLS per CoS ID (MEF 6.1 [3]) where the SLS has performance metrics defined in MEF 10.2 [7], MEF 10.2.1 [8] and this IA. Some performance metrics can be left as Not Specified (N/S) in the SLS. The Mobile Operator, as a customer of MEN, would benefit if the standard forwarding treatment of a CoS Frame Set, identified by the triple {S, CoS ID, PT}, is known at the UNI along with the desired performance metrics for the Mobile Backhaul service. This performance per CoS Frame Set is measured for the set of ordered UNI pairs in the CoS Frame Set.

MEF 23.1 [18] has defined CoS Labels, and CPOs for the performance metrics of each CoS Label. The intent is to enable a MEN Operator to offer a standard menu of CoS Name options and also allow a MEN Operator to define CoS Names other than CoS Labels.

Performance metrics for the Ethernet service across MEN, derived from the parameters in mobility standards, are generally included in the MEF CoS IA [18]. It is important to note that mobility standards specify performance from a User's equipment to a PCEF in the core. This scope is larger than the scope of Mobile Backhaul (i.e., UNI to UNI) defined in this IA.

In 2G and 3G Mobile Networks the Mobile Backhaul has been mostly for the logical interface between the RAN BS and RAN NC within a metro type distance (e.g. <250km). Additionally, in these legacy networks, the RAN BS with legacy TDM interfaces might use a CES across the MEN with additional delay due to the adaptation process of TDM frames into Ethernet frames. This can force additional constraints in performance across a MEN for delay and jitter.

With LTE or WiMAX, in addition to the S1 or R6 between a RAN BS and RAN NC, there is the X2 or R8 interface between RAN BS sites. The performance objectives for S1 or R6 can be significantly different from that for the X2 or R8. Some Mobile Operators can choose to have a centralized pool of S1/MME or ASN-GW servers and so the network topology might extend over a larger geographical distance (e.g. ~1000km). The X2 or R8, on the other hand, is between

nearest neighbors (up to 32, for example) within a given access or metro type distance (e.g. ~250km).

The NGMN Alliance [88] has specified some attributes such as for Frame Delay and Availability but other performance attributes has been left for further study. A maximum one-way delay of 10ms (though it was erroneously published as two-way) has been specified in the NGMN Alliance specification [88]. 3GPP TS 22.278 [58] mentions (in Section 8) a maximum delay comparable to fixed access with a recommended target of <5ms (ideal conditions). 3GPP TS 25.913 [70] mentions (in Section 6.2.2) an objective of <5ms (unload condition) and for a single data stream having small IP packets with a zero length payload. These objectives are expected to be refined by 3GPP as the architecture gets updated and the different functional components of LTE are better defined. LTE Advanced (Release 10) might introduce additional constraints for optimum spectrum use.

This IA recommends use of the Performance Tier 1 (PT1) CPOs for CoS Label H, M and L as defined in MEF 23.1 [18] for point to point services. Multipoint and Point to Multipoint services are expected to have CPOs specified in a future phase of MEF 23.1 [18]. The parameters for each performance objective are as defined in MEF 23.1 [18].

**[D22]** A MEF compliant Mobile Backhaul service **SHOULD** use PT1 as defined in MEF 23.1 [18].

**[O14]** A MEF compliant Mobile Backhaul service **MAY** use PT2 or PT3 as defined in MEF 23.1 [18].

**[D23]** A MEF compliant Mobile Backhaul service CoS Frame Set, associated with a Point to Point EVC and based on CoS Label, **SHOULD** have SLSs that are bounded by the CPOs in Table 6 of MEF 23.1 [18] and with Parameters in Table 5 of MEF 23.1 [18].

Table 8 in this IA specifies the one way CPOs for Point-to-Point Mobile Backhaul service with 1 or more CoS Names: H, M, L and H<sup>+</sup>. This is based on most stringent application or service requirements for Mobile Backhaul across all mobile technologies (2G to 4G) and thus will support any of the service (e.g. MEF 3, MEF 6.1) combinations across the same MEN. The table also contains an indication related to the bandwidth profiles (CIR and EIR) for each CoS Name. Less stringent values could be used for certain technologies, such as LTE or Wimax, when supported alone or under certain mix of services/applications and network assumptions.

CoS Name	Ingress Bandwidth Profile**	One Way CPO for Mobile Backhaul Service {S, CoS ID, PT}							
		FD	MFD	IFDV	FDR	FLR	Availability	L	B
<b>Very High</b> (H <sup>+</sup> )	CIR>0 EIR=0	≤10 ms	≤7 ms	N/S	A <sub>FDR</sub>	≤.01 % (i.e., 10 <sup>-4</sup> )	≥A <sub>Avail</sub>	≤A <sub>HLI</sub>	≤A <sub>CHLI</sub>
<b>High</b> (H)	CIR>0 EIR≥0	For CPO values across PT1 see Table 6 of MEF CoS IA [18].							
<b>Medium</b> (M)	CIR>0 EIR≥0	For CPO values across PT1 see Table 6 of MEF CoS IA [18].							
<b>Low</b> (L)	CIR≥0 EIR≥0*	For CPO values across PT1 see Table 6 of MEF CoS IA [18].							
<p>Notes:</p> <ul style="list-style-type: none"> <li>• A<sub>FDR</sub> values and parameters for H<sup>+</sup> to be included in a future phase of this IA. Values for FD and MFD might change depending on values for FDR.</li> <li>• For Synchronization traffic class (see Section 11.4.1) A<sub>IFDV</sub> for H<sup>+</sup> = N/S since FDR is used. Also, either MFD or FD needs to be used in SLS.</li> <li>• (*) both CIR = 0 and EIR = 0 is not allowed as this results in no conformant Service Frames. CIR=0 and EIR&gt;0 results in non-specified objectives.</li> <li>• (***) Ingress Bandwidth Profile for CoS Labels (H, M and L) are from Table 2 of MEF 23.1 [18].</li> <li>• CBS, EBS ≥ 8xMTU per MEF 13 [11]</li> <li>• See Table 5 of MEF CoS IA [18] for Parameters and values for H, M and L</li> </ul>									

Table 8: One way CPOs across PT for Point-to-Point Mobile Backhaul service

[D24] A MEF compliant Mobile Backhaul service mapped as H<sup>+</sup> CoS Name **SHOULD** use the bounds for the performance objectives and Bandwidth profile as specified in Table 8 of this IA.

Performance Attributes for which CPOs are not specified in MEF 23.1 [18] include Availability, HLI and CHLI.

### 11.6 EVC per UNI and per EVC Service Attributes

MEF 6.1[3] identifies the parameter values for Service Attributes of each service defined in that specification – E-Line, E-LAN, and E-Tree. The following table lists the EVC attributes with values from MEF 6.1[3] as well as from MEF 13[11] and additional constraints, if any, as specified in this IA.

11.6.1 VLAN based MEF 6.1 Services

EVC per UNI Service Attributes	MEF 6.1 EVPL	MEF 6.1 EVP-LAN	MEF 6.1 EVP-Tree	MEF 13 UNI Type 1.2 (UNI-N)	This IA (EVPL/EVP-LAN/EVP-Tree)
UNI EVC ID	A string formed by the concatenation of the UNI ID and the EVC ID.				No additional constraints
CE-VLAN ID / EVC Map	<b>MUST</b> specify mapping table of CE-VLAN IDs to the EVC ID.			<b>MUST</b> have a configurable CE-VLAN ID/EVC mapping table	No additional constraints
Traffic Management I-BWP per CoS ID (including CoS ID=EVC)	<b>OPTIONAL</b> . If supported, <b>MUST</b> specify <CIR, CBS, EIR, EBS, CM, CF>. <b>MUST NOT</b> be combined with any other type of ingress bandwidth profile.			<p><b>MUST</b> be able to support I-BWP per EVC</p> <p><b>SHOULD</b> be able to support per CoS I-BWP</p> <p><b>MUST</b> be able to support Color-blind, CIR&gt;0, CBS&gt;0 CBS <math>\geq</math> (8*MTU)</p>	Section 11.3 and 11.5 See various requirements and CPO table for CoS ID and BWP
Traffic Management: E-BWP per CoS ID (including CoS ID=EVC)	MUST be No	<b>OPTIONAL</b> . If supported, <b>MUST</b> specify <CIR, CBS, EIR, EBS, CM, CF>. <b>MUST NOT</b> be combined with any other type of egress bandwidth profile.			<p>Section 10.1 [O6] for Enhanced UNI attributes (E-BWP per UNI, per EVC and per CoS ID).</p> <p>Section 11.3 and 11.5 Requirements for CoS ID</p>

Table 9: EVC per UNI Service Attributes for VLAN based MEF 6.1 [3] Services

Per EVC Service Attributes	MEF 6.1 EVPL	MEF 6.1 EVP-LAN	MEF 6.1 EVP-Tree	MEF 13 UNI Type 1.2 (UNI-N)	This IA (EVPL/EVP-LAN/EVP-Tree)
EVC Type	<b>MUST</b> be Point-to-Point	<b>MUST</b> be Multipoint-to-Multipoint	<b>MUST</b> be Rooted-Multipoint	<b>MUST</b> be able to support Point-to-Point and Multipoint-Multipoint EVCs concurrently	Section 10.1 [D4] for Rooted Multipoint
EVC ID	An arbitrary string, unique across the MEN, for the EVC supporting the service instance.				No additional constraints
UNI List	<b>MUST</b> list the UNIs associated with the EVC.				Section 10.1 [D4] for Rooted Multipoint
	UNI type <b>MUST</b> be Root for each UNI	The UNI Type for at least 1 UNI <b>MUST</b> be Root. All UNIs that are not UNI Type Root <b>MUST</b> be UNI Type Leaf.			
Max # of UNIs	2	$\geq 2$			Section 11.1 See [D10] for minimum if multipoint EVC
EVC MTU Size	<b>MUST</b> be $\geq 1522$				No additional constraints See Section 11.2 for guidelines
CE-VLAN ID Preservation	Yes or No			<b>MUST</b> be able to support	No additional constraints
CE-VLAN CoS Preservation	Yes or No			<b>MUST</b> be able to support	Section 11.5.1 [D17] for VLAN based Services
Unicast /Multicast/ Broadcast Delivery	Deliver Unconditionally or Deliver Conditionally. If Delivered Conditionally, <b>MUST</b> specify the delivery criteria.			<b>MUST</b> be able to support	No additional constraints
L2CP Processing (passed to EVC)	<b>MUST</b> specify in accordance with Section 8 of [MEF 6.1]			<b>MUST/SHOULD</b> rules based on Protocol	Section 10.1 [R18] for L2CP Processing
EVC Performance	At least 1 CoS is <b>REQUIRED</b> . <b>MUST</b> specify CoS ID  <b>MUST</b> list values for each of the following attributes {Frame Delay, Frame Delay Variation, Frame Loss Ratio, and Availability} for each CoS, where Not Specified (N/S) is an acceptable value.				Section 11 Requirements on Set S, CoS Frame Set, CoS ID and EVC Performance including MEN or RAN Resiliency

Table 10: Per EVC Service Attributes for VLAN based MEF 6.1 [3] Services



11.6.2 Port based MEF 6.1 Services

Cells in Table 11 and Table 12 have been highlighted if MEF 6.1 [3] service attributes have different requirements than for VLAN based Services.

EVC per UNI Service Attributes	MEF 6.1 EPL	MEF 6.1 EP-LAN	MEF 6.1 EP-Tree	MEF 13 UNI Type 1.2 (UNI-N)	This IA (EPL/EP-LAN/EP-Tree)
UNI EVC ID	A string formed by the concatenation of the UNI ID and the EVC ID.				No additional constraints
CE-VLAN ID/EVC Map	All Service Frames at the UNI <b>MUST</b> map to a single EVC			<b>MUST</b> have a configurable CE-VLAN ID/EVC mapping table	No additional constraints
	Point-to-Point	Multipoint-to-Multipoint	Rooted-Multipoint		
Traffic Management: I-BWP per CoS ID (including CoS ID=EVC)	<b>OPTIONAL</b> . If supported, <b>MUST</b> specify <CIR, CBS, EIR, EBS, CM, CF>. <b>MUST NOT</b> be combined with any other type of ingress bandwidth profile.			<b>MUST</b> be able to support I-BWP per EVC <b>SHOULD</b> be able to support I-BWP per CoS <b>MUST</b> be able to support Color-blind, CIR>0, CBS>0 CBS ≥ (8*MTU)	Section 11.3 and 11.5 Requirements for CoS ID and BWP
Traffic Management: E-BWP per CoS ID (including CoS ID=EVC)	<b>MUST NOT</b> specify	<b>OPTIONAL</b> . If supported, <b>MUST</b> specify <CIR, CBS, EIR, EBS, CM, CF>. <b>MUST NOT</b> be combined with any other type of egress bandwidth profile.			Section 10.1 [O6] for Enhanced UNI attributes (E-BWP per UNI, per EVC and per CoS ID).  Section 11.3 and 11.5 Requirements for CoS ID

Table 11 EVC per UNI Service Attributes for Port based MEF 6.1 [3] Services

Per EVC Service Attributes	MEF 6.1 EPL	MEF 6.1 EP-LAN	MEF 6.1 EP-Tree	MEF 13 UNI Type 1.2 (UNI-N)	This IA (EPL/EP-LAN/EP-Tree)
EVC Type	<b>MUST</b> be Point-to-Point	<b>MUST</b> be Multipoint-to-Multipoint	<b>MUST</b> be Rooted-Multipoint	<b>MUST</b> be able to support Point-to-Point and Multipoint-Multipoint EVCs concurrently	Section 10.1 [D4] for Rooted Multipoint
EVC ID	An arbitrary string, unique across the MEN, for the EVC supporting the service instance.				No additional constraints
UNI List	<b>MUST</b> list the UNIs associated with the EVC.				No additional constraints
	UNI type <b>MUST</b> be Root for each UNI		The UNI Type for at least 1 UNI <b>MUST</b> be Root. All UNIs that are not UNI Type Root <b>MUST</b> be UNI Type Leaf.		Section 10.1 [D4] for Rooted Multipoint
Max # of UNIs	2	≥ 2			Section 11.1 See [D10] for minimum if multipoint EVC
EVC MTU Size	<b>MUST</b> be ≥ 1522				No additional constraints See Section 11.2 for guidelines
CE-VLAN ID Preservation	<b>Yes</b>			<b>MUST</b> be able to support	No additional constraints
CE-VLAN CoS Preservation	<b>Yes</b>			<b>MUST</b> be able to support	Section 11.5.1 [R43] for Port based Services
Unicast /Multicast/ Broadcast Delivery	<b>MUST</b> Deliver Unconditionally.		Deliver Unconditionally or Deliver Conditionally. If Delivered Conditionally, <b>MUST</b> specify the delivery criteria.	<b>MUST</b> be able to support	No additional constraints
L2CP Processing (passed to EVC)	<b>MUST</b> specify in accordance with Section 8 of [MEF 6.1]			<b>MUST/SHOULD</b> rules based on Protocol	Section 10.1 [R18] for L2CP Processing
EVC Performance	At least 1 CoS is <b>REQUIRED</b> . <b>MUST</b> specify CoS ID  <b>MUST</b> list values for each of the following attributes {Frame Delay, Frame Delay Variation, Frame Loss Ratio, and Availability} for each CoS, where Not Specified (N/S) is an acceptable value.				Section 11 - Requirements on Set S, CoS Frame Set, CoS ID and EVC Performance including MEN or RAN Resiliency

Table 12 Per EVC Service Attributes for Port based MEF 6.1 [3] Services

## 12. Synchronization

Synchronization is a generic concept of distributing common time and frequency references to all nodes in a network to align their time and frequency scales. In this IA timing is used as a single term to refer to either time or frequency. Synchronization is a key component in mobile technologies and different mobile technologies have different synchronization requirements. This phase of the IA addresses frequency synchronization only. Time and phase synchronization are for further study.

Synchronization is used to support mobile application and system requirements to minimize air interference, facilitate handover between base stations, and to fulfill regulatory requirements. Various mobile technologies stipulate that the radio signal must be generated in strict compliance with frequency, phase and time accuracy requirements, as illustrated in Table 13.

Application	Frequency (ppb)	Phase ( $\mu$ s)	Time ( $\mu$ s)	Reference Document
CDMA	$\pm 50$		$\pm 3$ (Traceable & Synchronous to UTC)	TIA/EIA-95-B [53]
CDMA2000	$\pm 50$		$\pm 10$ (>8hrs) when external timing source disconnected $\pm 3$ (Traceable & Synchronous to UTC)	3GPP2 C.S0002-E v2.0 [54] C.S0010-C v2.0 [56]
GSM	$\pm 50$ $\pm 100$ (pico BS)			ETSI TS 145.010 [54]
UMTS-FDD (WCDMA)	$\pm 50$ (Wide area BS) $\pm 100$ (Medium range BS) $\pm 100$ (Local area BS) $\pm 250$ (Home BS)	12.8 (MBSFN-3GPP Release 7/8)		3GPP Frequency: TS 25.104 [64] MBSFN: TS 25.346 [66]
UMTS-TDD (WCDMA)	$\pm 50$ (Wide area) $\pm 100$ (Local area) $\pm 250$ (Home eNB)	$\pm 2.5$ $\pm 1$ (between Macro eNB and Home eNB)		3GPP Frequency: TS 25.105 [65] Phase: TS 25.402 [67] Home eNB: TR 25.866 [69]

Application	Frequency (ppb)	Phase (μs)	Time (μs)	Reference Document
TD-SCDMA	±50	±3		3GPP TS 25.123[63]
LTE (FDD)	±50 (Wide area) ±100 (Local area) ±250 (Home eNB)	CDMA handover and Synchronized E-UTRAN GPS time ±10 (> 8hours) when external timing source disconnected		3GPP Frequency: TS 36.104 [72] Time: TS 36.133 [73]
LTE (TDD)	±50	≤ 3 (small cell) ≤ 10 (large cell)	CDMA handover and Synchronized E-UTRAN GPS time ±10 (> 8hours) when external timing source disconnected	3GPP Frequency: TR36.922 [75] Phase & Time: TS36.133 [73]
Mobile WiMAX	±2000 (i.e., 2ppm)	≤ ±1		IEEE 802.16-2009 [27] WMF-T23-001-R015v01 [86]

Table 13: Mobile Technology Synchronization Requirements

There are four main methods related to timing distribution from a PRC, i.e., timing source, to slave clocks at a RAN BS site:

1. Using GPS at RAN BS sites
2. Using a legacy TDM network with a TDM demarcation to RAN BS;
3. Using a MEN with Ethernet physical layer (Synchronous Ethernet) for links.

At the RAN BS site, in case the Synchronous Ethernet is terminated by a co-located transport equipment, the timing can be delivered from this transport equipment to the Radio Base Station via any other suitable standard interface (e.g. 2048 KHz according to G.703 [38])

4. Using a MEN with packet based methods and protocols such as PTP [28] or NTP [78], and ACR[85]/RTP [84].

At the RAN BS site, in case the timing, carried by the packet based method, is recovered by a co-located equipment the physical interface that can be used to distribute the timing to the Radio Base Station can be Synchronous Ethernet or any other suitable standard interface (e.g. 2048 KHz according to G.703 [38]).

Some of the above methods can provide only frequency synchronization (e.g. Synchronous Ethernet, legacy TDM network, ACR/RTP). Method 1 and 2 are outside of the scope of this IA. Method 3 and 4 for frequency synchronization are examined in the scope of this IA. Method 4 using PTP has been defined in ITU-T for frequency synchronization but use for phase or time

synchronization is yet to be specified. Method 4 for time and phase synchronization is out of scope for this phase of this IA.

Packet based methods are addressed in Sections 12.2. Synchronous Ethernet is addressed in Sections 12.3 and 10.4.

**12.1 Performance of synchronization architecture**

The performance of Synchronization distribution architecture of a SP is measured by compliance to jitter and wander limits, over certain time intervals, at the network interface offering the Synchronization service to a customer’s equipment. Both the choice of architecture, the level of performance impairments (i.e., FDR) and whether the synchronization service is directly terminated at the ‘End Equipment’, i.e., RAN BS, impact the jitter and wander limits at the network interface. In the context of this document the ‘End Equipment’ is the single base station at RAN BS. Also, when the UNI-C is not on the RAN BS then the frequency reference is delivered to a ‘Connected Equipment’, which might be a GIWF or other equipment in the RAN BS site, owned by the Mobile Operator.

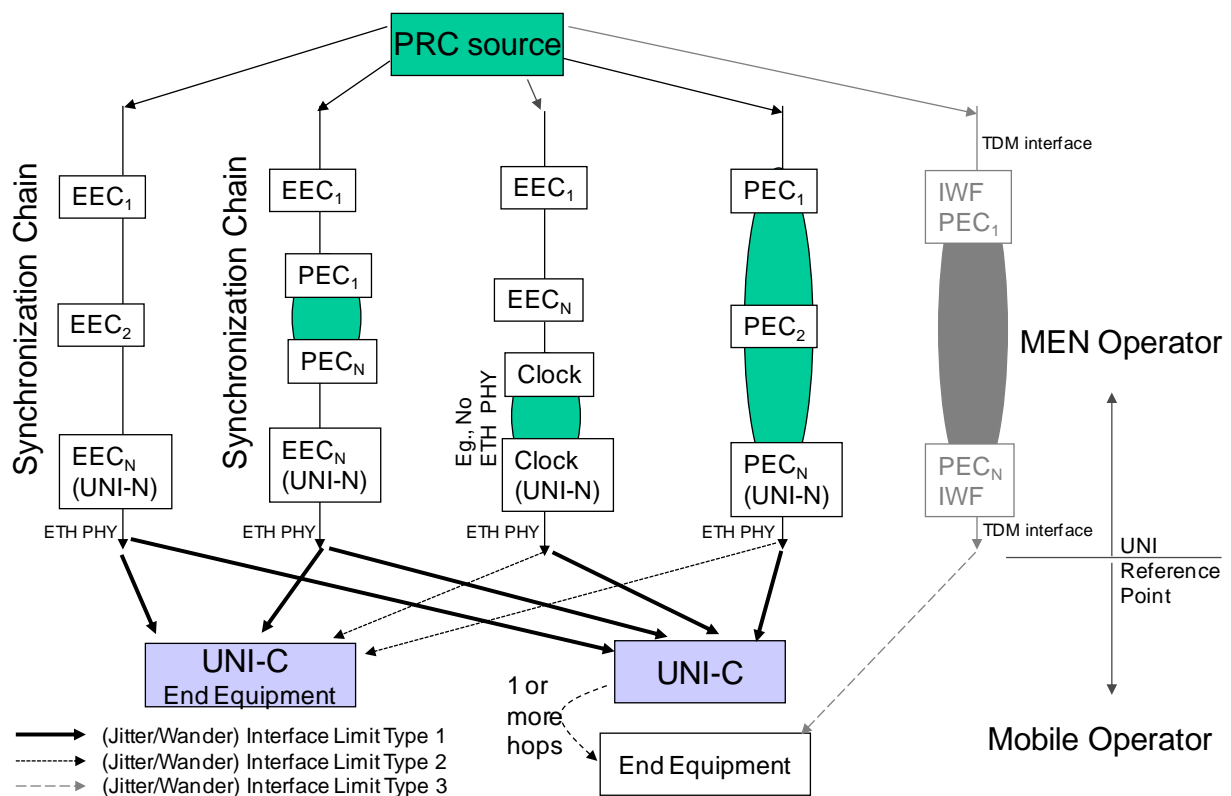

Figure 20: Synchronization Distribution Models from PRC source to RAN BS UNI

Figure 20 describes different scenarios in terms of synchronization distribution. The distribution chain can be entirely EECs or a mix of PECs and EECs or other clocks. This IA is not specifying the choice of the Synchronization architecture but is specifying interface limits for jitter and wander as follows:

1. Interface Limit Type 1: in this case, limits are described in Sections 12.2.1 and 12.3.1
2. Interface Limit Type 2: in this case limits are described in Sections 12.2.2 and 12.3.2;
3. Interface Limit Type 3: in this case limits are described in Section 12.2.3.

## 12.2 Packet Based Methods

A master-slave hierarchy, similar to model described for SDH in ITU-T G.803 [40], is used for packet based methods with Packet Equipment Clocks. The source clock is distributed from a Primary Reference Clock (PRC).

The focus of this IA is on frequency synchronization. There are two main use cases as shown in Figure 21:

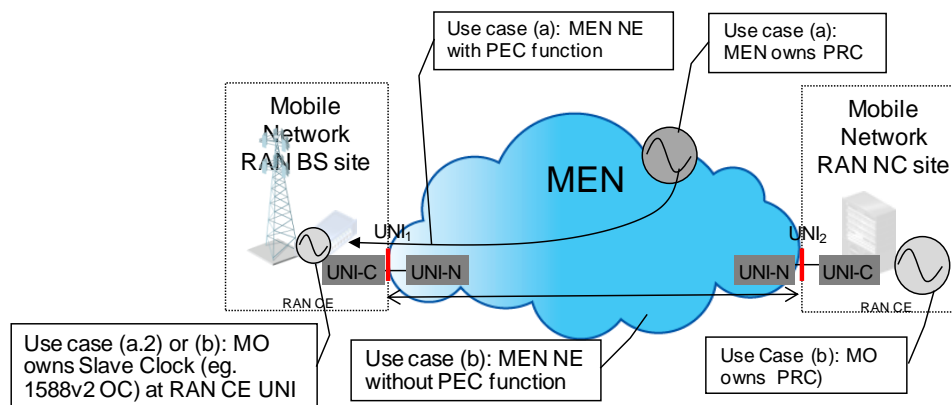

Figure 21: Use cases for packet method to distribute reference timing

- (a) MEN NE with PEC function: This functionality can be at the NEs with UNIs to RAN BSs or can also be present at other NEs within the MEN. Also, MEN provides the source clock (PRC) for the synchronization service. PEC in support of packet method (for non CES application) will be defined by ITU-T.
  - (a.1.) Slave clock at the MEN's UNI: The timing (frequency) information can be directly recovered from the frame arrival times, e.g., ACR, such as when CES (MEF 3 [1]) is the backhaul service to RAN BS with TDM interfaces. PEC functions, as shown in Figure 20, are used to translate the frame arrival rate in to a physical layer frequency over the Interface. Performance at the network interface is specified in Sections 12.2.1 and 12.2.2 with Ethernet demarcation as well as Section 12.2.3 with TDM demarcation using GIWF.
  - (a.2.) Slave clock in RAN BS: The MEN's PEC function at the UNIs, or any NE in MEN, participates in the protocol to provide additional information such as accumulated delay. This use case is for further study in a future phase of this IA.
- (b) MEN NE without PEC function: Mobile Operator owns timing source at RAN NC site(s) and slave clocks at RAN BSs as defined in ITU-T G.8265 [36] and, in case of PTP, with a IEEE1588 PTP profile for frequency distribution as defined in ITU-T G.8265.1 [37]. The MEN provides EVC with performance objectives in support of the synchronization traffic class. See Section 7.2 for EVC Types and Section 11 for EVC, CoS as well as



CPO for the CoS Name used to support packet based synchronization traffic class. The slave clock at RAN BSs can implement the PEC function to recover timing based on frame arrival rates or timestamps.

The UNI can be in Asynchronous Full Duplex Mode, i.e., Synchronous Ethernet mode of operation is disabled, when the MEN Operator is offering a Mobile Backhaul service to support the synchronization traffic class.

### 12.2.1 Network (UNI-N) Interface Limits for Packet based Methods

When a packet based synchronization service is provided to a UNI-C not on ‘End Equipment’ at RAN BS site, then Interface Limit Type 1 applies as shown in Figure 20. The requirement in terms of tolerance and level of accuracy for the recovered timing signal are as defined for deployment case 1 in ITU-T G.8261 (see clause 9.2.2.1) [32].

**[R46]** If UNI-C is not on ‘End Equipment’ at RAN BS site (i.e., RAN BS) then the Interface Limits for Jitter and Wander at the UNI-N **MUST** meet clause 9.2.2.1 EEC network limits as defined in ITU-T G.8261 for deployment case 1 [32]

### 12.2.2 Network (UNI-N) Interface Limits for Packet based Methods – Special Case

When a packet based synchronization service is provided to a UNI-C on ‘End Equipment’ at RAN BS site, then Interface Limit Type 2 applies as shown in Figure 20. The requirement in terms of tolerance and level of accuracy for the recovered timing signal are as defined for deployment case 2 in ITU-T G.8261 Recommendation (see clause 9.2.2.1) [32].

Typically, Base Stations are designed to tolerate wander as per G.823 / G.824 traffic masks of T1/E1 interfaces, Section 4.2.1 and Reference 16 in 3GPP TS 25.411 [63].

**[O15]** If UNI-C is on ‘End Equipment’ at RAN BS site (i.e., RAN BS), as defined in deployment case 2 of ITU-T G.8261 (see clause 9.2.2.1) [32], then the Interface Limits for Jitter and Wander at the UNI-N **MAY** be as defined by ITU-T G.823 clause 5 [47] or ITU-T G.824 clause 5 [48]

It is important to note that the looser criteria might be justified as long as the tolerance of the ‘End Equipment’ at BS site is met.

### 12.2.3 CES timing requirements

Use case 1a and 1b in Section 7.1.1 has a SP delivering Mobile Backhaul service at a TDM demarcation using a GIWF with TDM interface to the RAN CEs. The internal implementation details of the GIWF are out of the scope for this IA.

### 12.2.3.1 Network (TDM Interface) Interface Limits at Output of GIWF

Interface Limit Type 3, as shown in Figure 20, applies for the synchronization performance at the TDM demarcation.

**[R47]** The synchronization distribution **MUST** be such that jitter and wander measured at the output of the GIWF TDM interface meets the traffic interface requirements specified in ITU-T G.823 [47] for E1 and E3 circuits, and ITU-T G.824 [48] for DS1 and DS3 circuits and, in case of SDH signals, that meet the network limits for the maximum output jitter and wander at the relevant STM-N hierarchical interface as specified by ITU-T G.825 [49].

**[D25]** The synchronization distribution **SHOULD** be such that the wander budget allocated to the MEN and the GIWF as measured at the output of the GIWF TDM interface meets the traffic interface requirements of ITU-T G.8261, Deployment Case 2 [32].

### 12.2.3.2 Network (TDM Interface) Interface Limits at Input of GIWF

**[R48]** Jitter and wander that can be tolerated at the GIWF TDM input **MUST** meet the traffic interface requirements specified in ITU-T G.823 [47] for E1 and E3 circuits, and ITU-T G.824 [48] for DS1 and DS3 circuits and in case of SDH signals, the GIWF TDM **MUST** meet the jitter and wander tolerance for STM-N input ports as specified by ITU-T G.825 [49].

## 12.3 Synchronous Ethernet Methods

The IEEE 802.3-2008 standard [26] specifies that transmit clocks can operate with a frequency accuracy of up to +/- 100 ppm. The Synchronous Ethernet (SyncE) approach provides a mechanism to deliver a network traceable physical layer clock over IEEE 802.3 PHYs with EEC as specified in ITU-T G.8262 [33]. The SyncE model follows the same approach as was adopted for traditional TDM (PDH/SDH) synchronization i.e., utilizing the physical layer line signals, and implemented with similar engineering rules and principles. Synchronous Ethernet has also been designed specifically to inter-work with the existing SONET/SDH synchronization infrastructure. Note that Synchronous Ethernet is used to deliver frequency, but not phase or time of day.

The architectural aspects of Synchronous Ethernet are defined in ITU-T G.8261 [32]. SyncE provides the capability to provide an Ethernet clock that is traceable to a primary reference clock (PRC) as defined in ITU-T G.811 [42]. The details of the clock aspects of Synchronous Ethernet equipment can be found in the ITU-T G.8262 [33]. The latter specification defines the requirements for clock accuracy, noise transfer, holdover performance, noise tolerance and noise generation.

The frequency reference, delivered to the UNI-C at RAN BS site, is traceable to the MEN (Service Provider) PRC, as shown in Figure 22 below. The Mobile Operator can specify the required performance in terms of Network Interface Limit for Jitter and Wander at the UNI-N.

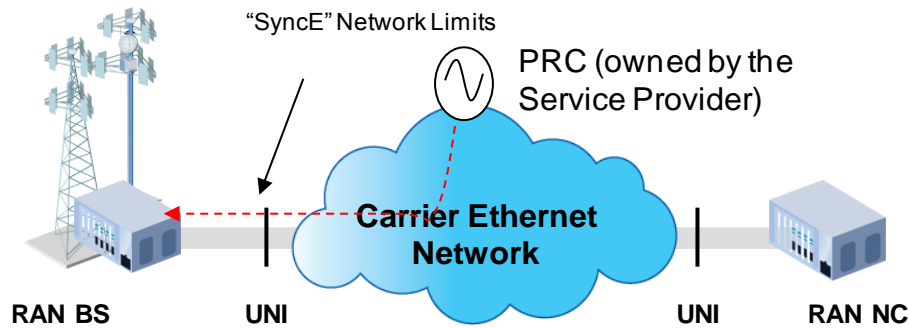

Figure 22: Example of Synchronization Service using Synchronous Ethernet

Further considerations on the use of Synchronous Ethernet in a multi-operator context can be found in ITU-T G.8264 Amendment 1 [34] for when Mobile Operator owns the PRC and MEN Operator is responsible for distribution of frequency reference to RAN BS sites.

### 12.3.1 Network (UNI-N) Interface Limits for Synchronous Ethernet Methods

When the Synchronization distribution across the MEN is a chain of EECs then Interface Limit Type 1 applies as shown in Figure 20. Two options are specified for Synchronous Ethernet equipment slave clocks (EECs). The first option, called EEC option 1, has been defined for networks using the 2048 kbps Synchronization hierarchy as defined in ITU-T G.813 option 1 for SDH networks [45][46]. The second option, called EEC option 2, applies to Synchronous Ethernet equipments that are designed to interwork with networks optimized for 1544 kbps synchronization hierarchy and has defined based on ITU-T G.813 option 2 [45][46] and G.812 Type IV [43][44].

**[R49]** At the output of the UNI-N at a RAN BS site, when Synchronous Ethernet service is provided to the UNI-C at RAN BS, the interface **MUST** meet clause 9.2.1 EEC network limits from ITU-T G.8261 [32]:

The interface limits in [R49] are defined assuming the MEN implements a Synchronous reference chain as described in clause 9.2.1 of ITU-T G.8261 [32]. Synchronization chains based on Synchronous Ethernet are according to ITU-T G.823 [47], ITU-T G.803 [40] and ITU-T G.824 [48] models. [R49] is also required when there are intermediate nodes between the UNI-N and the Base Station that are part of an EEC chain.

### 12.3.2 Network (UNI-N) Interface Limits - Special Cases

As mentioned in amendment 1 of clause 9.2.1 in ITU-T G.8261 [32] it is noted that the limits defined in ITU-T G.823 [47], ITU-T G.824 [48] and ITU-T G.825 [49] are generally applicable at all points in the Synchronization network. In some applications the MEN might not implement the Synchronization reference chain as described in clause 9.2.1 of ITU-T G.8261 [32]. These

are defined as the limits for traffic carrying signals as opposed to synchronization signals. In some cases, a SP might decide that these less stringent limits are more appropriate for their network due to the types of links and equipment in the reference chain. Often these limits are used in conjunction with CES implementations.

In access networks, it might be possible to recover frequency reference from an Ethernet signal that is generating jitter and wander according to the tolerance characteristics of the ‘Connected Equipment’. Across the MEN either there is no chain of EECs/SECs/ or it is a Synchronization distribution network where timing is not carried on every link by an Ethernet PHY. The frequency reference is, however, delivered with an Ethernet UNI to BS sites. In these cases it might not be appropriate to require the UNI to meet Synchronous Ethernet interface limits and Interface Limit Type 2 applies as shown in Figure 20. Typically, Base Stations are designed to tolerate wander as per ITU-T G.823 [47] and ITU-T G.824 [48] traffic masks of T1/E1 interfaces, Section 4.2.1 and Reference 16 in 3GPP TS 25.411 [63]

**[O16]** If the MEN does not implement the synchronization reference chain according to clause 9.2.1 of ITU-T G.8261 [32] then Network limit at the UNI **MAY** be as defined by ITU-T G.823 clause 5 [47] or ITU-T G.824 clause 5 [48]

It is important to note that the looser criteria might be justified when the SP determines that the ‘End Equipment’ at the BS site can tolerate the traffic limits as specified in [O16].

### 13. References

#### MEF Specifications

- [1] MEF 3, “Circuit Emulation Service Definitions, Framework and Requirements in Metro Ethernet Networks”
- [2] MEF 4, “Metro Ethernet Network Architecture Framework Part 1: Generic Framework”
- [3] MEF 6.1, “Ethernet Services Definitions - Phase 2”
- [4] MEF 6.1.1, “Layer 2 Control Protocol Handling Amendment to MEF 6.1”
- [5] MEF 8, “Implementation Agreement for the Emulation of PDH Circuits over Metro Ethernet Networks”
- [6] MEF 9, “Abstract Test Suite for Ethernet Services at the UNI”
- [7] MEF 10.2, “Ethernet Services Attributes - Phase 2”
- [8] MEF 10.2.1, Amendment to MEF 10.2
- [9] MEF 11, “User Network Interface (UNI) Requirements and Framework”
- [10] MEF 12.1, “Metro Ethernet Network Architecture Framework Part 2: Ethernet Services Layer”
- [11] MEF 13, “User Network Interface (UNI) Type 1 Implementation Agreement”
- [12] MEF 14, “Abstract Test Suite for Traffic Management Phase 1”
- [13] MEF 16, “Ethernet Local Management Interface”
- [14] MEF 17, “Service OAM Requirements & Framework”
- [15] MEF 19, “Abstract Test Suite for UNI Type 1”
- [16] MEF 20, “User Network Interface (UNI) Type 2 Implementation Agreement”
- [17] MEF 21, “Abstract Test Suite for UNI Type 2 Part 1 Link OAM”
- [18] MEF 23.1, “Class of Service Phase 2 Implementation Agreement”
- [19] MEF 24, “Abstract Test Suite for UNI Type 2 Part 2 E-LMI”
- [20] MEF 25, “Abstract Test Suite for UNI Type 2 Part 3 Service OAM”
- [21] MEF 27, “Abstract Test Suite for UNI Type 2 Part 5 - Enhanced UNI Attributes and Part 6 - L2CP Handling”
- [22] MEF 30, “Service OAM Fault Management Implementation Agreement”

#### IEEE Specifications

- [23] IEEE 802.1D-2004, “Part 3: Media Access Control (MAC) Bridges”
- [24] IEEE 802.1Q-2011, “Virtual Bridged Local Area Networks”
- [25] IEEE 802.1AX-2008, “Link Aggregation”
- [26] IEEE 802.3-2008, “Part 3: Carrier sense multiple access with collision detection (CSMA/CD) access method and physical layer specifications”

- [27] IEEE 802.16-2009, “Air Interface for Fixed and Mobile Broadband Wireless Systems”
- [28] IEEE 1588-2008, “Standard for A Precision Clock Synchronization Protocol for Network Measurement and Control Systems”

ITU-T Recommendations

- [29] ITU-T Y.1541, “Network Performance Objectives For IP-Based Services”, April 2002
- [30] ITU-T Y.1563, “ETH transfer performance and availability performance”, January 2009
- [31] ITU-T G.8260, “Definitions and terminology for synchronization in packet networks”, August 2010
- [32] ITU-T G.8261/Y.1361, Timing and Synchronization aspects in Packet Networks, April 2008
- [33] ITU-T G.8262/Y.1362 Timing Characteristics of Synchronous Ethernet Equipment Slave Clock (EEC), July 2010
- [34] ITU-T G.8264/Y.1364 Distribution of timing through packet networks, October 2008
- [35] ITU-T G.8264/Y.1364 Amendment 1, October 2010
- [36] ITU-T G.8265/Y.1365, “Architecture and requirements for packet based frequency delivery”, October 2010
- [37] ITU-T G.8265.1, “IEEE1588<sup>(TM)</sup> profile for telecom (frequency delivery without support from network nodes)”, June 2010
- [38] ITU-T G.703, “Physical/electrical characteristics of hierarchical digital interfaces”, November 2001
- [39] ITU-T G.781, “Synchronization layer functions”, September 2008
- [40] ITU-T G.803, “Architecture of transport networks based on the synchronous digital hierarchy (SDH)”, March 2000
- [41] ITU-T G.810, “Definitions and terminology for synchronization networks”, August 1996.
- [42] ITU-T G.811, “Timing characteristics of primary reference clocks”, September 1997
- [43] ITU-T G.812, “Timing requirements of slave clocks suitable for use as node clocks in synchronization networks”, June 2004
- [44] ITU-T G.812, Erratum 1 (2004), March 2009
- [45] ITU-T G.813, “Timing characteristics of SDH equipment slave clocks (SEC)”, March 2003
- [46] ITU-T G.813, Corrigendum 1 (2003), June 2005
- [47] ITU-T G.823, “The control of jitter and wander within digital networks which are based on the 2048 kbit/s hierarchy”, March 2000
- [48] ITU-T G.824, “The control of jitter and wander within digital networks which are based on the 1544 kbit/s hierarchy”, March 2000
- [49] ITU-T G.825, “The control of jitter and wander within digital networks which are based on synchronous digital hierarchy (SDH)”, March 2000



[50] ITU-T G.705, “Characteristics of plesiochronous digital hierarchy (PDH) equipment functional blocks”, October 2005

#### GSM & CDMA

[51] GSM 01.04 v8, “Abbreviations and Acronyms”, May 2000

[52] TIA IS-2000.1-A, “Physical Layer Standard for cdma2000 Spread Spectrum Systems”, March 2000

[53] TIA/EIA-95-B, “Mobile Station-Base Station Compatibility Standard for Wideband Spread Spectrum Cellular Systems”, (ANSI/TIA/EIA-95-B-99) (reaffirmed to TIA-95-B), March 1999

#### 3GPP and 3GPP2 Technical Specifications

[54] ETSI TS 145.010 v4.0.0.0, “GSM: Digital cellular telecommunication system (Phase 2+); Radio subsystem synchronisation (GSM 05.10)”

[55] 3GPP2 C.S0002-E v2.0 (2010-06), “Physical Layer Signaling Standard for cdma2000 Spread Spectrum Systems”,

[56] 3GPP2 C.S0010-C v2.0 (2006-03), “Recommended Minimum Performance Standards for cdma2000 Spread Spectrum Base Stations”

[57] 3GPP TS 21.905V9.4.0 (2009-12), “Vocabulary for 3GPP Specifications”

[58] 3GPP TS 22.278V8.10.0 (2009-12-19), “Service requirements for the Evolved Packet System (EPS)”

[59] 3GPP TS 23.060v10.4.0 (2011-05), “General Packet Radio Service (GPRS); Service description; Stage 2”

[60] 3GPP TS 23.107V9.1.0 (2010-06), “Quality of Service (QoS) concept and architecture”

[61] 3GPP TS 23.203V10.1.0 (2010-09), “Technical Specification Group Services and System Aspects; Policy and charging control architecture”

[62] 3GPP TS 23.236V6.0.0 (2005-01), Intra-domain connection of Radio Access Network (RAN) nodes to multiple Core Network (CN) nodes”

[63] 3GPP TS 25.123V9.0.0 (2009-12), “Requirements for support of radio resource management (TDD)”

[64] 3GPP TS 25.104V9.6.0 (2011-01), “Universal Mobile Telecommunication Systems (UMTS), UTRA BS FDD, Radio Transmission and Reception”

[65] 3GPP TS 25.105V9.2.0 (2010-09), “Universal Mobile Telecommunication Systems (UMTS), UTRA BS TDD, Radio Transmission and Reception”

[66] 3GPP TS 25.346.V9.1.0 (2010-04), “Introduction of the Multimedia Broadcast/Multicast Service (MBMS) in the Radio Access Network (RAN); Stage 2”

[67] 3GPP TS 25.402V9.0.0 (2009-12), “Synchronization in UTRAN Stage 2”

[68] 3GPP TS 25.411V9.0.0 (2010-01), “UTRAN Iu interface layer 1”

[69] 3GPP TR 25.866V9.0.0 (2010-01), “1.28Mcps TDD Home NodeB study item”

- [70] 3GPP TS 25.913V8.0.0, “Requirements for Evolved UTRA (E-UTRA) and Evolved UTRAN (E-UTRAN)”
- [71] 3GPP TS 25.933V5.4.0 (2004-1), ”IP Transport in UTRAN”
- [72] 3GPP TS 36.104V9.6.0 (2011-01), ” Evolved Universal Terrestrial Radio Access (E-UTRA); Base Station (BS) radio transmission and reception”
- [73] 3GPP TS36.133V9.0.0 (2009-06), “Evolved Universal Terrestrial Radio Access (E-UTRA); Requirements for support of radio resource management”
- [74] 3GPP TS 36.300V9.4.0 (2010-06), “Evolved Universal Terrestrial Radio Access (E-UTRA) and Evolved Universal Terrestrial Radio Access Network (E-UTRAN); Overall description; Stage 2”
- [75] 3GPP TR36.922V9.1.0 (2010-06), “Evolved Universal Terrestrial Radio Access (E-UTRA); TDD Home eNode B (HeNB) Radio Frequency (RF) requirements analysis”

#### Broadband Forum (BBF) Specifications

- [76] IP/MPLS Forum 20.0.0, "MPLS in Mobile Backhaul Networks Framework and Requirements Technical Specification" (October 2008)

#### IETF

- [77] RFC 791, “Internet Protocol”
- [78] RFC 1305, “Network Time Protocol (Version 3) – Specification, Implementation, and Analysis”
- [79] RFC 2119, “Key words for use in RFCs to Indicate Requirement Levels”
- [80] RFC 2401, “Security Architecture for IP”
- [81] RFC 2460, “Internet Protocol, Version 6 (IPv6) Specification”
- [82] RFC 2474, “Definition of the Differentiated Services Field (DS Field) in the IPv4 and IPv6 Headers”
- [83] RFC 3386, “Network Hierarchy and Multilayer Survivability”
- [84] RFC 3550, “RTP: A Transport Protocol for Real-Time Applications”
- [85] RFC 4197, “Requirements for Edge-to-Edge Emulation of Time Division Multiplexed (TDM) Circuits over Packet Switching Networks”

#### Wimax Forum Specifications

- [86] WMF-T32-001-R016v01, “WiMAX Forum Network Architecture - Architecture Tenets, Reference Model and Reference Points Base Specification Stage 2. 2010-11-30”
- [87] WMF-T23-001-R015v02, “WiMAX Forum Mobile System Profile Specification, Release 1.5 Common Part, 2011-07-14”

#### NGMN Alliance

- [88] NGMN Alliance, “NGMN Optimized Backhaul Requirements”, August 2008  
([http://www.ngmn.org/uploads/media/NGMN\\_Optimised\\_Backhaul\\_Requirements.pdf](http://www.ngmn.org/uploads/media/NGMN_Optimised_Backhaul_Requirements.pdf))

## Appendix A. Generic Inter-working Function (Informative)

This Appendix provides an informative definition of the Generic Inter-working Function.

The Generic Inter-working Function (GIWF) provides functionality that allows RAN CE devices with a Non-Ethernet I/F to send traffic over an Ethernet UNI. A detailed description of the GIWF is outside the scope of this document; however, the IWF definition described in MEF 3 [1] can be used as an example for a PDH based Non-Ethernet I/F.

Non-Ethernet I/F is a generic term that refers to a non-Ethernet based interface, e.g. ATM or TDM. A GIWF is only needed if the RAN CE has a Non-Ethernet I/F and therefore can not directly connect to the UNI. Figure 23 is based on the IWF defined in MEF 3 and illustrates where the GIWF would be located.

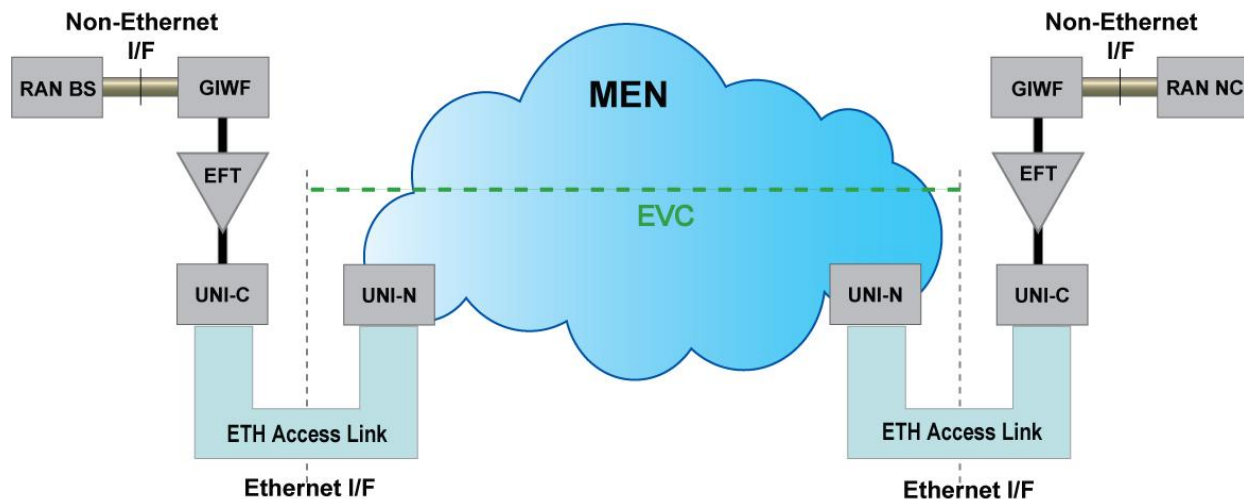

Figure 23: Generic Inter-working Function

The GIWF might perform none, part of or all the UNI-C functions. If the GIWF does not perform all the functions expected by the UNI-C then it is expected that another device is located in front of the GIWF towards the MEN that performs the remaining UNI-C functions. All ingress Service Frames from the GIWF through the Ethernet Flow Termination (EFT) point towards the UNI is conformant to the Ethernet frame format as defined in MEF 10.2 [7] and this IA of the UNI type that is used, e.g. MEF 13 [9] for UNI Type 1. The GIWF identifies traffic in a manner to allow the EFT to apply the proper CE-VLANs and/or CoS ID marking. Although the GIWF might perform some UNI-C functions, this does not imply that the GIWF must be owned and operated by the mobile network operator.

With respect to synchronization, the GIWF might contain functions to support synchronization over the MEN. The details of these functions are outside the scope of this IA but the interface requirements are specified in Section 12.2.3.

## Appendix B. Mobile Backhaul User Traffic Classes (Informative)

Several traffic classes are identified for Mobile Backhaul. WCDMA, CDMA2000, LTE and WiMAX<sup>3</sup> standards define their own user service classes. Examples of the WCDMA and WiMAX user service classes are shown below. Each user service class has performance requirements.

Traffic Class	Example Application	Fundamental Characteristics
<b>Conversational class</b>	Voice	- Conversational RT - Preserve time relation (variation) between information entities of the stream Conversational pattern (stringent and low delay )
<b>Streaming class</b>	Streaming video	- Streaming RT - Preserve time relation (variation) between information entities of the stream
<b>Interactive class</b>	Web browsing	- Interactive best effort - Request response pattern - Preserve payload content
<b>Background</b>	Background download of emails	- Background best effort - Destination is not expecting the data within a certain time - Preserve payload content

Table 14: WCDMA User Service Classes (3GPP 23.107 [57])

Traffic Class	MEF CoS Name	Example Application	Fundamental Characteristics
<b>UGS (Unsolicited Grant Service )</b>	H	T1/E1 constant rate traffic or VoIP (without silence suppression)	For real-time uplink service flows that transport fixed-size data packets on a periodic basis, such as T1/E1 and Voice over IP without silence suppression
<b>rtPS (real-time Polling Service)</b>	H	Video streaming	For real-time UL service flows that transport variable-size data packets on a periodic basis, such as streaming moving pictures.
<b>Extended rtPS</b>	H	VoIP	Unicast uplink grants in an unsolicited manner where allocations are dynamic
<b>nrtPS (non-real-time Polling Service)</b>	H or M	FTP	Unicast polls on a regular basis, assuring that the UL service flow receives request opportunities even during network congestion. For applications that require guaranteed data rate but are insensitive to delays
<b>BE (Best Effort)</b>	L	Background download of emails, web browsing	For applications with no data rate or delay requirements

Table 15: WiMAX User Service Classes (IEEE 802.16 [27])

WiMAX traffic classes, shown in Table 15, can be mapped to the MEF CoS Names based on the characteristics identified in Table 7 and the availability of 2 or 3 or 4 CoS Names at the UNI. For example, delay sensitive (e.g. FD and IFDV) traffic such as UGS traffic class for voice or rtPS for real time video streaming can use the H CoS Name and the CPOs as specified in Table 8. Traffic classes that are loss sensitive, but can be insensitive to delays, such as nrtPS could use M CoS Name, if available, or could be mapped to H CoS Name if only 2 CoS Names. Traffic

<sup>3</sup> 3GPP does not define traffic classes for GSM.

classes with no performance metrics can use L CoS Name along with the option to be marked as discard eligible (yellow color).

LTE has specified the service classes in Section 6.1.7 of 3GPP TS 23.203 [61] and shown in Table 16. The forwarding treatment for performance is in terms of a QoS Class Identifier (QCI) value that is a composite indicator of the priority as well as performance for the service class. There are 9 different service classes using QCI. The transport modules of eNB and aGW are responsible to map the QCI to the transport layer’s priority so as to get the required forwarding treatment across the Mobile Backhaul network.

Table 16 specifies the Packet Delay Budget (not the same as the MEF metrics as FD or MFD or FDR) and Packet Error Loss Rate (not the same as MEF metric FLR) that each service class sees from the user’s equipment (UE) to the PCEF as shown in Figure 6.1.7-1 of 3GPP TS 23.203 [61]. The sections UE to RAN BS and RAN NC to PCEF are not relevant for the CPOs specified in Section 11.5.2 for the Mobile Backhaul service. The Mobile Backhaul service scope is as discussed in Sections 3 and 7 of this IA. Also, Note 2 in Table 16 mentions that the PELR is specified when network is assumed to be ‘non congestion’ state. So, the performance metrics mentioned in Table 16 are more applicable for the air interface, i.e., UE to RAN BS. **Since these metrics are not defined the same as the MEF metrics and the scope is different from this IA the objectives stated are not easily compared to MEF CPOs.**

QCI	Resource Type	Priority	Packet Delay Budget (PDB) (See NOTE 1)	Packet Error Loss Rate (PELR) (See NOTE 2)	Example Services
1	GBR	2	100 ms	10 <sup>-2</sup>	Conversational Voice
2		4	150 ms	10 <sup>-3</sup>	Conversational Video (Live Streaming)
3		3	50 ms	10 <sup>-3</sup>	Real Time Gaming
4		5	300 ms	10 <sup>-6</sup>	Non-Conversational Video (Buffered Streaming)
5	Non-GBR	1	100 ms	10 <sup>-6</sup>	IMS Signalling
6		6	300 ms	10 <sup>-6</sup>	Video (Buffered Streaming) TCP-based (e.g., www, e-mail, chat, ftp, p2p file sharing, progressive video, etc.)
7		7	100 ms	10 <sup>-3</sup>	Voice, Video (Live Streaming) Interactive Gaming
8		8	300 ms	10 <sup>-6</sup>	Video (Buffered Streaming) TCP-based (e.g., www, e-mail, chat, ftp, p2p file sharing, progressive video, etc.)
9		9			

Following NOTES are from [61]  
 NOTE 1: A delay of 20 ms for the delay between a PCEF and a radio base station should be subtracted from a given PDB to derive the packet delay budget that applies to the radio interface. This delay is the average between the case where the PCEF is located "close" to the radio base station (roughly 10 ms) and the case where the PCEF is located "far" from the radio base station, e.g. in case of roaming with home routed traffic (the one-way packet delay between Europe and the US west coast is roughly 50 ms). The average takes into account that roaming is a less typical scenario. It is expected that subtracting this average delay of 20 ms from a given PDB will lead to desired end-to-end performance in most typical cases. Also, note that the PDB defines an upper bound. Actual packet delays - in particular for GBR traffic - should typically be lower than the PDB specified for a QCI as long as the UE has sufficient radio channel quality.  
 NOTE 2: The rate of non congestion related packet losses that may occur between a radio base station and a PCEF should be regarded to be negligible. A PELR value specified for a standardized QCI therefore applies completely to the radio interface between a UE and radio base station.

Table 16: Standardized QCI Characteristics for LTE Service Classes 3GPP TS 23.203 [61]

In addition, there are control and management plane traffic types that are not included in the tables above. One way to handle these traffic types could be to bundle them into a single service class, e.g. control class. The performance expectation for this class is high availability with low frame delay and frame loss. However there may be sufficient variance in the traffic characteristics (e.g., bursty long frames for firmware upgrade vs periodic short frame FM/PM messages) and performance requirements e.g., (file transfer vs essential FM message) between different types of management traffic to justify use multiple CoS Names

Synchronization signaling could be delivered using the control class, but this would mean that control class would need to conform to the requirements of the synchronization method used to distribute timing. Alternatively, synchronization could be delivered using a separate class that would typically have stringent performance requirements.



## Appendix C. Mobile Backhaul Services (Informative)

The scope of this Appendix is to provide information describing several Use Cases for delivering Mobile Backhaul with MEF 6.1 [3] services. These services run between the RAN CEs at RAN BS sites or at RAN NC sites as defined by this IA.

The use cases presented here assume that the backhaul network (MEN) is owned by a single operator (assumption made for Phase 2). These use cases are not meant to be exhaustive; additional use cases addressing different assumptions are for further study.

This section describes 5 different scenarios and related assumptions for delivering data and control plane traffic; they are referred in the following as:

1. EVP Line per RAN BS
2. EVP Tree per group of RAN BSs
3. EVP-Tree per Service
4. EVP-LAN per group of RAN BSs
5. Different EVC types for different mobile interfaces

In addition, the Appendix describes two alternatives for delivering management plane traffic.

### C.1 Use Case 1: EVP Line per RAN BS

Use Case 1 illustrates a Mobile Backhaul network with a distinct EVP Line service between each RAN BS and RAN NC with the following configurations:

- The RAN NC uses a configured CE-VLAN ID to identify a RAN BS in the Mobile Backhaul network. The CE-VLAN ID is mapped at the RAN NC UNI-N and at the RAN BS UNI-N to the EVC associating the UNIs at the RAN BS and RAN NC. This implies that each RAN NC UNI can distinguish up to four thousand distinct RAN BSs.
- At the RAN NC side the CE-VLAN ID assignment is performed at the UNI-C; at the RAN BS side the CE-VLAN ID assignment can be either performed at the UNI-C or at the UNI-N, according to which option - described later in this section - is selected.
- Bundling is disabled which means that all traffic types are sent on the same CE-VLAN ID.
- Multiple Classes of Service can be supported; they are differentiated through either PCP or DSCP marking. CoS ID is identified by <EVC+PCP> or <EVC+DSCP>. In this use case CoS ID preservation is enabled and 4 classes of service are supported.

The EVP Line service is used for the Abis traffic in 2G networks, for the Iub traffic in 3G networks, and for the S1 traffic in LTE and for the R6 traffic in WiMAX. The EVP Line service can be used for the X2 traffic also in LTE, assuming that the X2 traffic reaches the RNC and it is responsible to route it back to the required RAN-BS.

Both Figure 24 and Table 17 show an example of how Ethernet Services can be delivered in the Mobile Backhaul according to the assumptions made for the present use case.

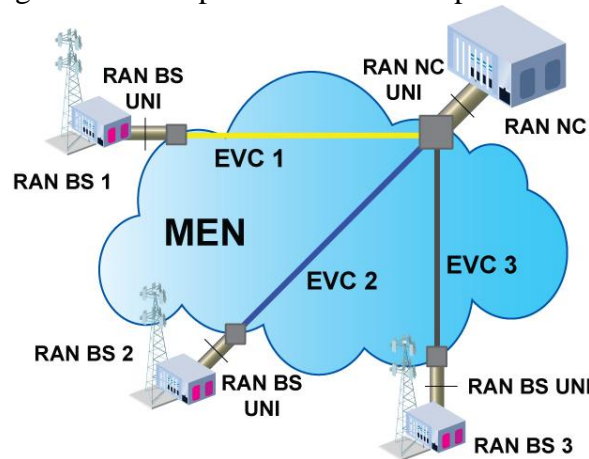

Figure 24: EVP Line per RAN BS – Use Case 1

EVC ID	EVC End Points	Ethernet Service
EVC_1	BS 1, NC	EVP-Line
EVC_2	BS 2, NC	EVP-Line
EVC_3	BS 3, NC	EVP-Line

Table 17: EVP Line per RAN BS – Use Case 1

Use Case 1 might also take into consideration additional factors that result in four possible options, each considering a different service frame format at the RAN BS UNI-C:

- **Option A:** The CE-VLAN ID Preservation Attribute is enabled and the RAN BS UNI-C transmits/receives tagged service frames to/from the RAN BS UNI-N with the CE-VLAN ID preconfigured for the RAN BS itself; either PCP or DSCP values specify different Classes of Service.
- **Option B:** The CE-VLAN ID Preservation Attribute is disabled and the RAN BS UNI-C transmits/receives untagged service frames to/from UNI-N where they are mapped to the default CE-VLAN ID; DSCP values specify different Classes of Service. A default mapping of untagged service frames is configured at each RAN BS UNI-N.
- **Option C:** The CE-VLAN ID Preservation Attribute is disabled and the RAN BS UNI-C transmits priority tagged service frames<sup>4</sup> towards the UNI-N, where they are mapped to the default CE-VLAN ID, and receives untagged frames; PCP values specify different Classes of Service. A default mapping of priority tagged service frames is configured at each RAN BS UNI-N.
- **Option D:** The CE-VLAN ID Preservation Attribute is disabled and BS UNI-C transmits/receives tagged service frames to/from UNI-N with a preconfigured CE-VLAN ID, identical for each BS. Either PCP or DSCP values specify different Classes of Service.

<sup>4</sup> The priority tagged frame is defined by MEF 10.2 as a Service Frame with an IEEE 802.1Q tag in which the CE-VLAN ID field is set to 0.

Options B, C and D can ease the configuration of the RAN BS because they are agnostic to the CE-VLAN ID value used to identify Service Frames in the Mobile Backhaul.

Table 18 shows an example of the CE-VLAN ID / EVC mapping for each option and the configuration both at the RAN BS UNI-N and at the RAN NC UNI-N:

EVC ID	CE-VLAN ID at RAN BS UNI-N				CE-VLAN ID at RAN NC UNI-N
	Option A	Option B	Option C	Option D	
EVC_1	10	*(5)	*	25	10
EVC_2	20	*	*	25	20
EVC_3	30	*	*	25	30

Table 18: Example of CE-VLAN ID \ EVC mapping both at RAN BS UNI-N and at RAN NC UNI-N

Table 19 shows an example of how to differentiate multiple Classes of Service with PCP values for MEF standard CoS Labels [18] on a given EVC:

CoS ID <EVC+PCP>	Class of Service	Traffic Class Example
< EVC_ID+6>	Instance of H <sup>+</sup> class	Synchronization
< EVC_ID+5>	Instance of H class	Conversational, Signaling and Control
< EVC_ID+3>	Instance of M class	Streaming
<EVC_ID+1>	Instance of L class	Interactive and Background

Table 19: Example of multiple CoS IDs based on <EVC+PCP> – Use Case 1

The CoS ID Preservation attribute should be enabled for each option in order to simplify configuration.

Note that the CoS ID per <EVC> model can also be supported by Use Case 1 if the assumption to use a single EVP Line per RAN BS that supports multiple services is removed. According to this new assumption each RAN BS can support multiple EVP Lines whereby mobile traffic classes can be grouped into different EVCs. Each EVP Line is mapped to a unique CE-VLAN ID and so each CE-VLAN ID identifies a specific set of services between the RAN NC and a specific RAN BS.

## C.2 Use Case 2: EVP Tree per group of RAN BSs

Use Case 2 explores the option of associating the UNIs at RAN CEs using an EVP-Tree service with the following configurations:

<sup>5</sup> The symbol \* indicates the CE-VLAN ID value used at the UNI for both untagged and priority tagged frames.

- Groups of  $k_i$ <sup>6</sup> RAN BSs are uniquely identified at the RAN NC by a CE-VLAN ID<sup>7</sup>. Associating several RAN BSs to the same CE-VLAN ID allows one to overcome the VLAN ID address space limitation affecting the previous use case.
- An EVP-Tree is established between the RAN BSs (acting as leaves) belonging to the same group and the RAN NC (acting as root) and it is associated to the CE-VLAN ID reserved for that group of RAN BSs
- At the RAN NC side the CE-VLAN ID assignment is performed at the UNI-C; at the RAN BS side the CE-VLAN ID assignment can be either performed at the UNI-C or at the UNI-N, according to which option (A, B, C or D) is chosen (as per Use Case 1) when deploying EVP-Tree services.
- Bundling is disabled which means that all traffic types are sent on the same CE-VLAN ID.
- Multiple Classes of Service can be supported; they are differentiated through either PCP or DSCP marking. CoS ID is identified by <EVC+PCP> or <EVC+DSCP>. In this use case CoS ID preservation is enabled and 4 classes of service are supported.

The EVP-Tree service is used for the Abis traffic in 2G, the Iub traffic in 3G and for the S1 traffic in LTE.

The EVP-Tree service can be used also for the S1-Flex interface that allows each RAN-BS to be connected to multiple RAN-NC's in a pool, to support network redundancy and load balancing. For that several RAN-NC shall be part of the service as root points.

Figure 25 shows an example about how Ethernet Services can be delivered in the Mobile Backhaul according to the assumptions made for the present use case.

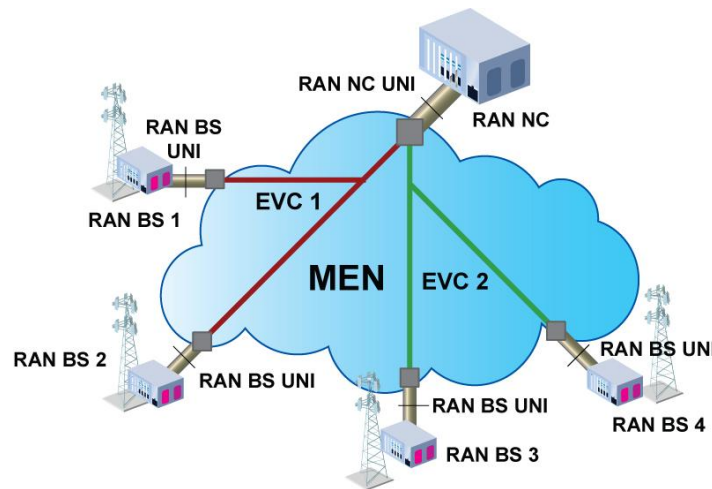

Figure 25: EVP-Tree per group of RAN BSs – Use Case 2

<sup>6</sup>  $k_i$  indicates the number of RAN BSs belonging to the  $i$ -th group. This scenario can be extended to the case of a single group including all the RAN BSs connected to the RAN NC.

<sup>7</sup> Inside each group each RAN BS is uniquely identified by its own MAC address. Security issues are not taken into account in this Appendix.

EVC ID	EVC End Points	Ethernet Service
EVC_1	BS 1, BS2, NC	EVP-Tree
EVC_2	BS 3, BS 4, NC	EVP-Tree

Table 20: EVP Tree per group of RAN BSs – Use Case 2

Comparing Use Case 2 with the previous one it is possible to note that Use Case 2 replicates for a group of RAN BSs, using EVP Tree services, what Use Case 1 does for a single BS, using a single EVP Line. This leads to the following conclusion: the same four options (A, B, C and D) previously described and focusing on different frame format at the RAN BS UNI-C can also be applied to Use Case 2. Refer to Table 18 and Table 19 to get an example about the CE-VLAN ID / EVC mapping and CoS ID definition for the present scenario.

### C.3 Use Case 3: EVP LAN per group of RAN BSs

Use Case 3 explores the option of associating the UNIs at RAN CEs using an EVP-LAN service with the following configurations:

- Groups of  $k_i$ <sup>8</sup> RAN BSs are uniquely identified at the RAN NC by a CE-VLAN ID<sup>9</sup>.
- An EVP-LAN is established between the RAN BSs belonging to the same group and the RAN NC and it is associated to the CE-VLAN ID reserved for that group of RAN BSs
- At the RAN NC side the CE-VLAN ID assignment is performed at the UNI-C; at the RAN BS side the CE-VLAN ID assignment can be either performed at the UNI-C or at the UNI-N, according to which option (A, B, C or D) is chosen (as per Use Case 1) when deploying EVP-LAN services.
- Bundling is disabled which means that all traffic types are sent on the same CE-VLAN ID.
- Multiple Classes of Service can be supported; they are differentiated through either PCP or DSCP marking. CoS ID is identified by <EVC+PCP> or <EVC+DSCP>. In this use case CoS ID preservation is enabled and 4 classes of service are supported.

The EVP-LAN service is used for the Abis traffic in 2G, the Iub traffic in 3G and for the S1 and X2 traffic in LTE. The EVP LAN provides direct connectivity between RAN BS neighbours that are in the same group. X2 connectivity between RAN BSs in different group shall be provided by the RAN NC routing functionality.

The EVP-LAN service can be used also for the S1-Flex interface that allows each RAN-BS to be connected to multiple RAN-NC's in a pool, to support network redundancy and load balancing.

<sup>8</sup>  $k_i$  indicates the number of RAN BSs belonging to the  $i$ -th group. This scenario can be extended to the case of a single group including all the RAN BSs connected to the RAN NC.

<sup>9</sup> Inside each group each RAN BS is uniquely identified by its own MAC address. Security issues are not taken into account in this Appendix.

Figure 26 shows an example about how Ethernet Services can be delivered in the Mobile Backhaul according to the assumptions made for the present use case.

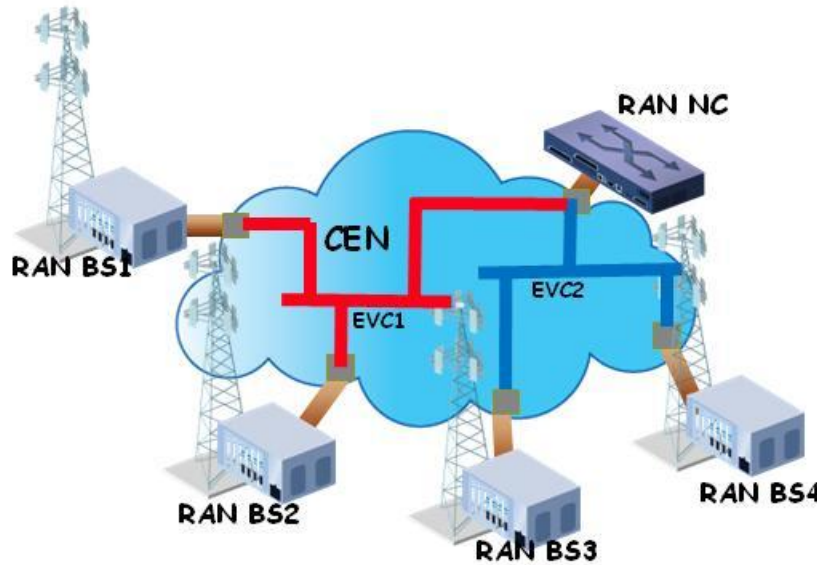

Figure 26: EVP-LAN per group of RAN BSs – Use Case 3

EVC ID	EVC End Points	Ethernet Service
EVC_1	BS 1, BS2, NC	EVP-LAN
EVC_2	BS 3, BS 4, NC	EVP-LAN

Table 21: EVP LAN per group of RAN BSs – Use Case 3

#### C.4 Use Case 4: EVP Tree per Service

Use Case 4 illustrates a scenario where traffic classes are separated over multiple EVP-Tree services. The configurations for this service include:

- Each CE-VLAN ID can be configured, to uniquely identify a unique service, which in turn, uniquely identifies a set of traffic classes. This means that the same set of traffic classes (i.e. voice, data, RAN signalling etc.) running between the RAN NC and two or more different RAN BSs will be identified by the same CE-VLAN ID value.
- RAN NCs will be configured as Roots and RAN BSs as Leaves
- The CE-VLAN ID tagging is performed both at the RAN BS UNI-C and at the RAN NC UNI-C. CE-VLAN ID preservation is enabled.
- Traffic classes can be differentiated through their CE-VLAN IDs; alternatively the same CE-VLAN ID can be associated to a set of traffic classes and either PCP or DSCP values can be used to differentiate among them. In other words CoS ID can be defined either per <EVC> or per <EVC+PCP> or per <EVC+DSCP>. CoS ID preservation is enabled.
- Suggested to support 4 CoS.



Figure 27 illustrates an example of how Ethernet services can be delivered in the Use Case 4.

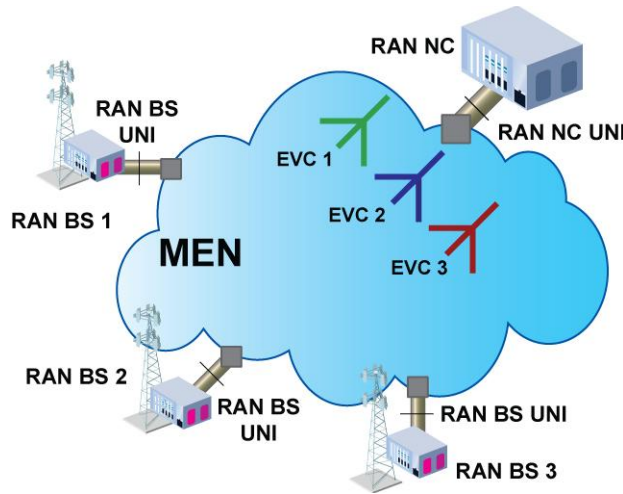

Figure 27: CE-VLAN ID per service – Use Case 4

EVC ID	EVC End Points	Ethernet Service
EVC_1	BS 1, BS2, BS 3, NC	EVP-Tree
EVC_2	BS 1, BS2, BS 3, NC	EVP-Tree
EVC_3	BS 1, BS2, BS 3, NC	EVP-Tree

Table 22: EVP Tree per Service – Use Case 4

In this scenario each RAN BS can be served by different EVP-Trees. Each RAN BS at its own UNI-C transmits/receives tagged frames to/from UNI-N with different CE-VLAN IDs: one for each different set of traffic classes. At RAN BS UNI-N each CE-VLAN ID is mapped to the correspondent EVP Tree service.

Table 23 shows through an example about the CE-VLAN ID / EVC mapping both at RAN BS UNI-N and at RAN NC UNI-N:

EVC ID	CE-VLAN ID at RAN BS UNI-N	CE-VLAN ID at RAN NC UNI-N
EVC_1	10	10
EVC_2	20	20
EVC_3	30	30

Table 23: Example of CE-VLAN ID\EVC mapping both at RAN BS UNI-N and at RAN NC UNI-N

Table 24 shows through an example how CoS Names could be defined in this scenario:

CoS ID	Class of Service	i.e. Traffic Class
<EVC_1>	Instance of H <sup>+</sup> class	Synchronization
<EVC_2+5>	Instance of H class	Conversational,
<EVC_2+5>	Instance of H class	Signaling and Control
<EVC_3+3>	Instance of M class	Streaming
<EVC 3+1>	Instance of L class	Interactive and Background

Table 24: CoS ID both per <EVC> and per <EVC+PCP> - Use Case 4

### C.5 Use Case 5: Different EVC for different mobile interfaces

Use Case 5 explores the option of having different EVC's for different interfaces between RAN BSs and between RAN BS and RAN NC.

Co-location of several mobile technologies (like co location of 2G and 3G) might require different EVC for the different interfaces. For example one EVC for the Abis traffic interface in 2G, and second EVC for the Iub traffic interface in 3G.

LTE or WiMAX defines the S1 or R6 interface between RAN BS and RAN NC, and X2 or R8 interface between RAN BS neighbors, Each of those interfaces can be mapped to a different EVC with a CE-VLAN to EVC map at the UNI-N (for example, the S1 or R6 interface is mapped to an EVP-Line EVC, and the X2 or R8 interface can be mapped to an EVP-LAN EVC).<sup>10</sup>

Figure 28 shows an example of how Ethernet Services can be delivered in LTE Mobile Backhaul according to the assumptions made for the present use case.

<sup>10</sup> In this use case the RAN-BS performs necessary service classification for the S1 and X2 interfaces and maps them to different sets of CE-VLAN's.

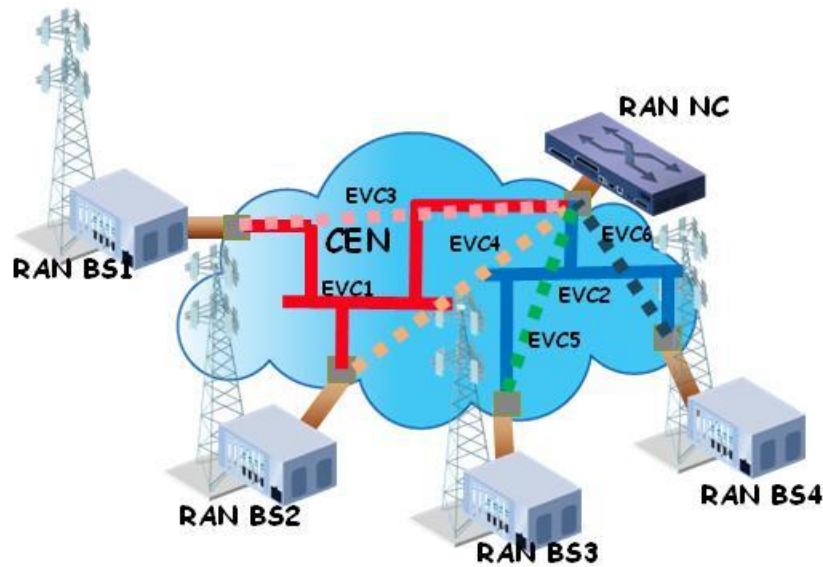

Figure 28: EVP-LAN for X2 and EVP-Line for S1 – Use Case 5

EVC ID	EVC End Points	Ethernet Service
EVC_1	BS 1, BS2, NC	EVP-LAN
EVC_2	BS 3, BS 4, NC	EVP-LAN
EVC_3	BS 1, NC	EVP-Line
EVC_4	BS 2, NC	EVP-Line
EVC_5	BS 3, NC	EVP-Line
EVC_6	BS 4, NC	EVP-Line

Table 25: EVP Tree per group of RAN BSs – Use Case 5

This use case allows connectivity between RAN BSs in the same group. This connectivity can be used for the X2 or R8 interface in LTE or WiMAX networks. The EVP LAN provides direct connectivity between neighbours RAN BS that are in the same group.

X2 connectivity between RAN BSs in different group shall be provided by the RAN NC routing functionality.

Use Case 5 can also take into consideration additional factors that result in two possible options, each considering a different service frame format at the RAN BS UNI-C:

- **Option A:** The CE-VLAN ID Preservation Attribute is enabled and the RAN BS UNI-C transmits/receives tagged service frames to/from the RAN BS UNI-N with the CE-VLAN ID preconfigured for the RAN BS itself.
- **Option B:** The CE-VLAN ID Preservation Attribute is disabled and BS UNI-C transmits/receives tagged service frames to/from UNI-N with a preconfigured CE-VLAN ID, identical for each BS.

Option B, can ease the configuration of the RAN BS because it is agnostic to the CE-VLAN ID value used to identify Service Frames in the Mobile Backhaul.

Table 26 shows an example of the CE-VLAN ID / EVC mapping for each option and the configuration both at the RAN BS UNI-N and at the RAN NC UNI-N:

EVC ID	CE-VLAN ID at RAN BS UNI-N		CE-VLAN ID at RAN NC UNI-N
	Option A	Option B	
EVC_1	10	25	10
EVC_2	20	25	20
EVC_3	30	35	30
EVC_4	40	35	40
EVC_5	50	35	50
EVC_6	60	35	60

Table 26: Example of CE-VLAN ID \ EVC mapping both at RAN BS UNI-N and at RAN NC UNI-N

### C.6 Configuration alternatives for Management plane

Management plane traffic can be distributed in the Mobile Backhaul according to two main alternatives<sup>11</sup> that apply to all the use cases previously presented:

- Over the same Ethernet Services instantiated for data and control plane traffic, reserving a specific CoS Name for management traffic
- Over a separate Ethernet Service exclusively for management.

A proposal of Ethernet Service configuration related to the latter alternative is presented in the following text.

The main general assumptions are:

- Management plane is associated to a CE-VLAN ID common to all the RAN BSs and RAN NCs.
- CE-VLAN ID tagging is performed at the UNI-C at both the RAN BS and the RAN NC.
- Different Classes of Service are supported and are differentiated through either PCP or DSCP marking.

In terms of Ethernet Services, the following configuration could be used for management:

- An EVP-Tree, associated to the common CE-VLAN ID, is established between the RAN NC (acting as root) and all the RAN BSs (acting as leaves)
- CoS IDs either per <EVC+PCP> or per <EVC+DSCP>.

<sup>11</sup> Since the management plane is an issue under discussion at several Standards Development Organizations, this Appendix does not preclude description of new alternative proposals in addition to those ones already presented in this chapter.

Both Figure 29 and Table 27 present an example about how management traffic can be treated in Mobile Backhaul.

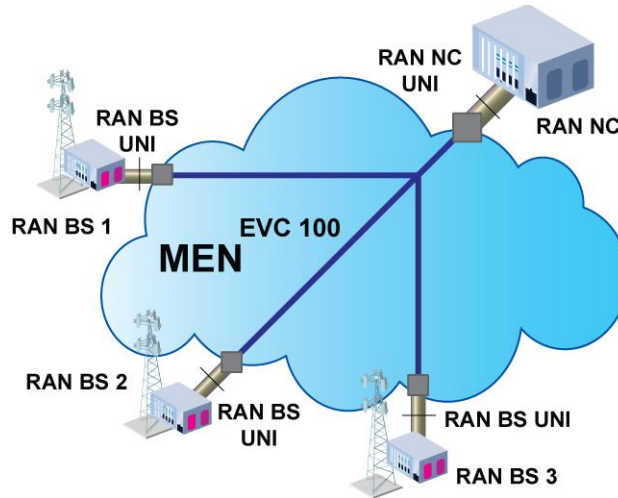

Figure 29: Ethernet Service for Management plane

EVC ID	EVC End Points	Ethernet Service	CE-VLAN ID at RAN BS UNI-N	CE-VLAN ID at RAN NC UNI-N
EVC 100	BS1, BS2, BS3, NC	EVP-Tree	150	150

Table 27: Ethernet Service configuration for Management plane – An example

Tagging is performed at the UNI-C at both the RAN BS and RAN NC sides. One-to-one mapping between CE-VLAN IDs and EVCs is done at the UNI-N at both the RAN BS and the RAN NC sides.

Enabling the CE-VLAN ID Preservation Attribute, the same VLAN ID value is maintained over the EVC easing the configuration of all the appliances in Mobile Backhaul.

The EVC reserved for management can support multiple Classes of Service: both Figure 30 and Table 28 below show such an example.

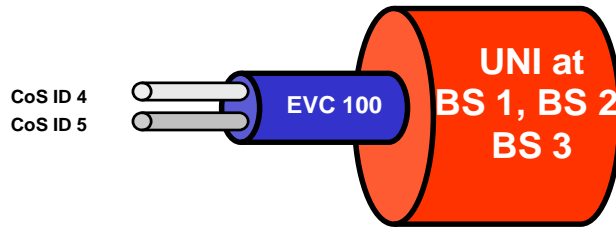

Figure 30: Multiple CoS IDs on the EVC reserved for Management traffic

CoS ID <EVC+PCP>	Class of Service	i.e. Traffic Class
< EVC 100+6 >	Instance of H <sup>+</sup> class	High Priority Mgt
< EVC_100+5 >	Instance of H class	Low Priority Mgt

Table 28: Example of Multiple CoS IDs on the EVC reserved to Management

The CoS ID Preservation Attribute should be enabled in order to simplify the configuration of the Mobile Backhaul.